



**EUROPEAN
JUDO
UNION**

GENERAL HANDBOOK

Edition April 2023

Table of contents

1. Basic Principles	6
2. Calendar	6
3. Ranking List	6
4. Age Groups	6
5. Weight Categories	6
6. Time Duration of Contests	7
7. Competition schedule and system	7
7.1 Competition format	7
7.2 Competition system	8
8. Participation	10
9. Entries	10
10. Accreditation	11
10.1 Facilities and technical requirements	11
10.2 Accreditation System & Access Control	13
10.2.1 European Judo Cups & European Judo Open	13
10.2.2 European Championships	14
11. Draw	16
11.1 Procedure and timing	16
11.2 Seeding	17
11.3 Facilities and technical requirements	17
11.3.1 Requirements for European Judo Cups:	18
11.3.2 Requirements for European Judo Open & European Judo Championships:	18
12. Weigh-in	18
12.1 General regulations	18
12.2 Official Weigh-in Procedure	19
12.3 Random weigh-in	21
12.4 Random Weigh-in Procedure	21
13. Competition Venue	21
13.1 Venue	21
13.2 Training Venue	22

13.3	Warm Up Area and Judogi Control	22
13.4	Entry to Field of Play	24
13.5	Field of Play and Competition Area	24
13.6	Security	25
13.7	Rehearsal	25
13.8	Lighting	26
13.9	Cleaning & Officials table	26
14.	<i>Transportation</i>	26
14.1	President	26
14.2	EJU Delegates (Executive Members, Commissioners, Staff)	26
14.3	VIPs	26
14.4	Referees	26
14.5	Athletes and Coaches	27
15.	<i>Marketing</i>	27
15.1	Basic principles.....	27
15.2	Competition Venue Dressing	28
15.3	Decoration of Official & Technical tables.....	28
15.4	Printed sponsor boards	29
15.5	Coach Boxes	30
15.6	Roll-up banners and Deco Flags.....	33
15.7	Direction System.....	34
15.8	Tatami Stickers.....	35
15.9	LED Boards	35
15.10	Medal wall and Awarding Podium	36
15.11	Medals.....	38
15.12	Trophies	38
15.13	Sponsor stickers for back numbers	39
15.14	Reserve Judogis and Event backnumbers	39
15.15	Dress code volunteers	39
15.16	Vests for photographer & medical team	39
15.17	Promotional materials	40
15.18	Event promotion - Press conference & PR (before event)	40

16. Media	41
16.1 Press tribune & Media Centre	41
16.2 Photographers	41
16.3 Mixed Zone	42
16.4 Media services.....	42
16.5 Event promotion - Press Conference & PR (before event)	42
17. IT Requirements - European Championships	43
17.1 Introduction.....	43
17.2 Before start... ..	43
17.3 Equipment + Transport	43
17.4 Accreditation cards.....	44
17.5 Accreditation Setup	44
17.6 Draw	45
17.7 Power for Referee Replay & Live Streaming.....	45
17.8 Electricity points.....	46
17.9 Laptops	46
17.10 Monitors	47
17.11 Local Network	48
17.12 Internet Network	49
17.13 Local Network 10 GBit	50
17.14 Scoreboards.....	50
17.15 Scoreboard Operators	51
17.16 Gong & Audio Set-up	51
17.17 Video Cabling	52
17.17.1 Option when TV providing front camera signals from all mats on all days	52
17.17.2 Option when front camera signals are NOT provided by TV for entire event	53
17.18 Video Camera operators.....	54
17.19 Streaming Studio.....	54
17.20 Information system.....	55
17.21 Referee Radios	55
17.22 After Competition	56
18. TV Requirements	57
18.1 Production Philosophy of the International Feed.....	57

18.2	Delivery of the International Feed.....	57
18.3	Programmes.....	58
18.4	Production Plan for the Production of the International Feed.....	60
18.5	Recordings	60
18.6	Coordination of International Rights Holders Requirements	60
18.6.1	Commentary Positions.....	60
18.6.2	Pre and Post Fight Unilaterals	61
18.6.3	Telecom installations.....	61
18.6.4	Other Services	61
19.	<i>IT Requirements - European Open</i>	62
19.1	Introduction.....	62
19.2	Before start... ..	62
19.3	Equipment + Transport	62
19.4	Accreditation cards.....	63
19.5	Accreditation Setup	63
19.6	Draw	64
19.7	Power for Referee Replay & Live Streaming.....	64
19.8	Electricity points.....	65
19.9	Laptops	65
19.10	Monitors	66
19.11	Local Network	66
19.12	Internet Network	67
19.13	Local Network 10 GBit	68
19.14	Scoreboards.....	69
19.15	Scoreboard Operators	69
19.16	Gong & Audio Set-up	70
19.17	Video Cabling	71
19.18	Video Camera operators.....	71
19.19	Streaming Studio.....	72
19.20	Information system.....	72
19.21	CARE System	73
19.22	Referee Radios	73
19.23	After Competition	74

20. IT Requirements - European Cup.....	75
20.1 Introduction.....	75
20.2 Accreditation cards.....	75
20.3 Accreditation Setup	76
20.4 Draw	76
20.5 Power	77
20.6 Electricity points.....	77
20.7 Laptops	78
20.8 Monitors	78
20.9 Local Network	79
20.10 Internet Network	80
20.11 Local Network 10 GBit.....	81
20.12 Scoreboards.....	81
20.13 Scoreboard Operators	82
20.14 Video Cabling	82
20.15 Video Camera operators.....	83
20.16 Streaming Studio (optional)	83
20.17 Information system.....	84
20.18 CARE System	84
20.19 Referee Radios	85

1. Basic Principles

In general, all EJU events are held following all rules of IJF, i.e. IJF Sport and Organisation Rules (SOR) and IJF Event Organisation Guide (EOG). Specific regulations for EJU events will be defined in the following chapters.

All regulations set in IJF SOR about Integrity Rules, Match Fixing, Insurance and Civil Liability, Gender Control, Minor Athletes and Nationality are fully valid without any restriction exceptions for all EJU events.

2. Calendar

EJU is organising the following types of events, either as part of respective IJF tours or separately:

- European Judo Cups Cadets (IJF Cadet World Ranking events)
- European Judo Cups Juniors (IJF Junior World Ranking events)
- European Judo Cups Seniors
- European Judo Open (IJF World Ranking events)
- European Judo Championships Cadets (Individual & Mixed Teams)
- European Judo Championships Juniors (Individual & Mixed Teams)
- European Judo U23 Championships (Individual & Mixed Teams)
- European Judo Championships Seniors (Individual)
- European Judo Championships Seniors Mixed Teams
- European Club Championships - Europa League
- European Club Championships - Champions League

3. Ranking List

In addition to IJF World Ranking Lists (cadets, juniors, seniors), EJU is maintaining an EJU Senior Ranking List.

4. Age Groups

Athletes under 15 years are not allowed to compete in any official EJU event. The lower age limit for all EJU competitions is 15 years (calendar year).

The following age categories are recognized and used by the EJU:

- Cadets - boys and girls under 18, age 15, 16 and 17 years (calendar year)
- Juniors - men and women under 21, age 15 to 20 years (calendar year)
- U23 - men and women under 23, age 15 to 22 years (calendar year)
- Seniors - men and women, lower age limit only of 15 years (calendar year)

5. Weight Categories

In all EJU events weight categories are used for the various age groups as specified by IJF SOR, chap. 1.11. For the age group of U23 the weight categories of seniors are used.

6. Time Duration of Contests

U18, U21, U23, Seniors (women & men): 4 min

Golden Score without a time limit

7. Competition schedule and system

7.1 Competition format

The EJU competitions normally consist of two sessions, the preliminaries and the final block. The competition phases that take place in the sessions depends on the type of event. Any changes to this will be agreed and approved by the EJU Sport Commission.

European Judo Cups Cadets		
	Female	Male
Day 1	-40 kg, -44 kg, -48 kg, -52 kg	-50 kg, -55 kg, -60 kg, -66 kg
Day 2	-57 kg, -63 kg -70 kg, +70 kg	-73 kg, -81 kg, -90 kg, +90 kg
European Judo Cups Juniors		
	Female	Male
Day 1	-63 kg, -70 kg, -78 kg, +78 kg	-60 kg, -66 kg, -73 kg
Day 2	-48 kg, -52 kg, -57 kg	-81 kg, -90 kg, -100 kg, +100 kg
European Judo Cups Seniors		
	Female	Male
Day 1	-48 kg, -52 kg, -57 kg, -63 kg	-60 kg, -66 kg, -73 kg
Day 2	-70 kg, -78 kg, +78 kg	-81 kg, -90 kg, -100 kg, +100 kg
European Judo Open women		
	Female	Male
Day 1	-48 kg, -52 kg, -57 kg, -63 kg	
Day 2	-70 kg, -78 kg, +78 kg	
European Judo Open men		
	Female	Male
Day 1		-60 kg, -66 kg, -73 kg
Day 2		-81 kg, -90 kg, -100 kg, +100 kg
European Judo Open women & men		
	Female	Male
Day 1	-48 kg, -52 kg, -57 kg, -63 kg	-60 kg, -66 kg, -73 kg
Day 2	-70 kg, -78 kg, +78 kg	-81 kg, -90 kg, -100 kg, +100 kg

European Judo Championships Cadets		
	Female	Male
Day 1	-40 kg, -44 kg, -48 kg	-50 kg, -55 kg, -60 kg
Day 2	-52 kg, -57 kg, -63 kg	-66 kg, -73 kg
Day 3	-70 kg, +70 kg	-81 kg, -90 kg, +90 kg
Day 4	Mixed Team	
European Judo Championships Juniors		
	Female	Male
Day 1	-48 kg, -52 kg, -57 kg	-60 kg, -66 kg
Day 2	-63 kg, -70 kg	-73 kg, -81 kg
Day 3	-78 kg, +78 kg	-90 kg, -100 kg, +100 kg
Day 4	Mixed Team	
European Judo U23 Championships		
	Female	Male
Day 1	-48 kg, -52 kg, -57 kg, -63 kg	-60 kg, -66 kg, 73 kg
Day 2	-70 kg, -78 kg, +78 kg	-81 kg, -90 kg, -100 kg, +100 kg
Day 3	Mixed Team	
European Judo Championships Seniors		
	Female	Male
Day 1	-48 kg, -52 kg, -57 kg	-60 kg, -66 kg
Day 2	-63 kg, -70 kg	-73 kg, -81 kg
Day 3	-78 kg, +78 kg	-90 kg, -100 kg, +100 kg
Day 4	Mixed Team (if not held as separate event)	

7.2 Competition system

All EJU events are held using a competition system recognised by IJF (See IJF SOR, section 14).

The following systems are used in EJU events according to number of participants:

- Cadet European Judo Cups, Junior European Judo Cups, Senior European Judo Cups:
 - o 6 and more entries: Double repechage
 - o If there are one (1) to five (5) athletes the low numbers competition systems and rules apply.

Low numbers competition system rules

No	Medals awarded	WRL points awarded (if applicable)	Competition System
5*	Gold, silver and one bronze	First, second, one third and one or two fifth (only if the athlete won one contest in the round robin) place.	The athletes will be divided as follows: Pool A – 3 athletes will compete in a round robin system. The winner will go to the final, the second will compete against the loser from pool B in the bronze medal contest. Pool B – 2 athletes will compete for a place in the final
4*	Gold, silver and one bronze	First, second and one third place.	Pool system with two (2) single contests, then a contest between the two (2) losers for the single bronze medal and a contest between the two (2) winners for the gold and silver medals.
3*	Gold, silver and one bronze (for individuals, if one contest was won)	First, second and third (only if one contest was won) place.	A round robin system will be held in the elimination round. The best and the second best will compete in a final for the gold and silver medal. The third athlete will be awarded the single bronze (for individuals, only if one contest was won).
2*	Gold (individuals)	First place.	One final contest.
1*	None	No	No competition

*Participation points given (if applicable).

If only one (1) athlete passes the weigh-in there will be no competition

- European Judo Open:
 - o Quarter Final Repechage System
- Cadet European Judo Championships (Individual & Mixed Team)
 - o Double Repechage
- Junior European Judo Championships (Individual & Mixed Team)
 - o Quarter Final Repechage System
- U23 European Judo Championships (Individual)
 - o Quarter Final Repechage System
- Senior European Judo Championships (Individual)
 - o Quarter Final Repechage System
- Senior European Mixed Team Judo Championships
 - o Quarter Final Repechage System
- European Club Championships - Europa League
 - o Full Repechage System
- European Club Championships - Champions League
 - o Quarter Final Repechage System

8. Participation

All *European Judo Cups* (cadet, junior, senior) as well as all *European Judo Open* are open for all EJU and IJF Member Federations. There is no limit in the number of participants for each weight category for every federation, neither in European Judo Cups nor in European Judo Open. The competitors must be of the same nationality as the National Federation, which enters them (IJF rules on Nationality fully apply).

All European Judo Championships (cadet, junior, U23, senior, mixed team) are open for all EJU Member Federations. The competitors must be of the same nationality as the National Federation, which enters them (IJF rules on Nationality fully apply). The limits of the number of participants for each weight category for every federation are as follows:

	Max. number per category	Max. number per gender	Max. number of teams
Cadet European Judo Championships	2	10	1
Junior European Judo Championships	2	9	1
U23 European Judo Championships	2	9	1
Senior European Judo Championships (Indiv.)	2	9	
Senior European Mixed Team Judo Championships			1

Participation of foreign athletes and quotas for *Europa League* and *Champions League* are specified in the General Rules for European Club Championships.

9. Entries

All participants and delegates must be in possession of a valid IJF ID Card and registered for this event in the IJF Registration System (JUDOBASE): <https://admin.judobase.org/> respecting the following deadlines:

European Judo Cups (cadet, junior, senior)	Friday 2 weeks before the competition, 23:59 CET
European Judo Open	
European Judo Championships (cadet, junior, U23)	Monday of the week before the competition, 23:59 CET
Senior European Judo Championships	20 days before the first competition day, 23:59 CET

Deadlines for participation in a team competition will be specified in the respective outlines and rules.

After the deadline further registrations (late entries, replacements) are exclusively handled during accreditation according to the following rules:

	NO IJF Official ID Card	Late entry IJF Official ID Card: YES	Replacement IJF Official ID Card: YES
Athletes	ENTRY NOT POSSIBLE	60 €	0 €
Other delegates (Head of delegation, Coaches, ...)	REPLACEMENT NOT POSSIBLE	0 €	0 €

Please note:

- After the inscription deadline, replacements or additions can only be made on spot during accreditation.
- Above mentioned late entry fee has to be paid in cash on spot.
- Persons without IJF ID Card can only be entered on spot, if IJF ID Card will be ordered until end of Accreditation.
- Persons, who are banned by their Federation, cannot be entered as late entry or replacement.
- For late entries or replacements in European Championships also a letter from the National Federation is required.

10. Accreditation

At least one team official and maximum two must attend the accreditation in order to confirm the delegation. Without this confirmation in time, a nation will not be put into draw and will not be allowed to compete. Each Head of Delegation must be present during the control of participants. Passports or photocopies of passports from all competitors must be available on request (national ID Card showing nationality, picture and date of birth or a copy is also accepted). The competitors must not be present at the nationality control. An EJU accreditation card with a photograph will be issued to competitors and officials.

Times for accreditation:

<i>European Judo Cups</i> (cadet, junior, senior)	Day before event 10:00 - 17:00
<i>European Judo Open</i>	
<i>European Judo Championships</i> (cadet, junior)	Two days before event 17:00 - 20:00 Day before event 10:00 - 14:00
<i>U23 European Judo Championships</i>	Day before event 10:00 - 14:00
<i>Senior European Judo Championships</i>	Two days before event 14:00 - 20:00 Day before event 10:00 - 13:00

10.1 Facilities and technical requirements

See IT Requirements - Accreditation Setup

Numbers refer to paragraphs on previous pages: 0. EJU Head Office 1. Registration & Accreditation / 2. Control of Nationality / 3. EJU Marketing / 4. EJU Finances / 5. Organiser Finances (Fast

Track)/ 6. Organiser Finances / 7. Anthems & Flags (for EJO & ECups) / 8. Departures / 9. Collection of ID Cards & Info Pack; a. Tea / Coffee / Water / b. waiting area outside of the room

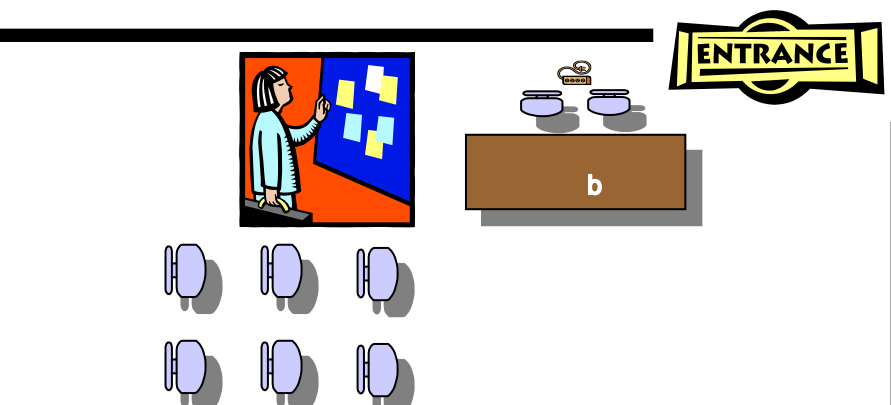
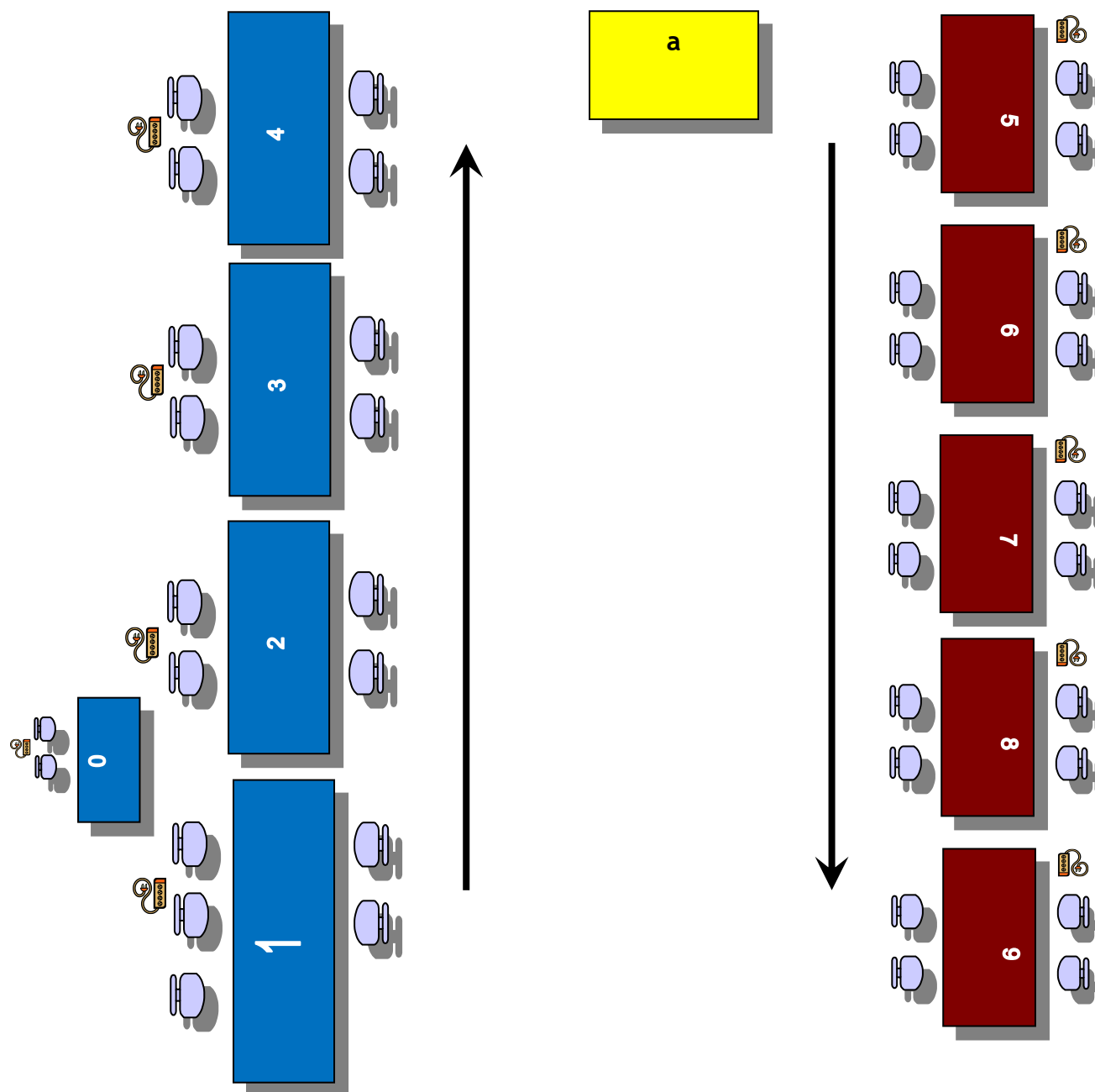

















10.2 Accreditation System & Access Control

10.2.1 European Judo Cups & European Judo Open

Accreditation	Symbol	Function	Access
		EJU Team	All areas
		Security	
		Referee	
		Local organiser (+FOP)	
		Competitor	Delegation areas including Field of Play
		Coach	
		Doctor	
		Team Official (not in coach chair)	
		Physiotherapist	Delegation NOT Field of Play
		Judoka	
		Local organiser (Not FOP)	
		Photographer	Photo areas including Field of Play
		TV	Media areas NOT Field of Play
		Written Press	
		EJU VIP & LOC VIP, Nat. Fed. President	Delegation areas including Field of Play (not in coach chair), VIP areas and tribune

		<p>Local organiser and EJU guest</p>	<p>Delegation tribune/ non-ticketed spectator tribune</p>
---	---	--------------------------------------	---

10.2.2 European Championships

Accreditation	Symbol	Function	Access
		EJU Team	All areas
		Security	
		Referee	
		Local organiser (+FOP)	
		Competitor	Delegation areas including Field of Play
		Coach	
		Doctor	
		Team Official (not in coach chair)	
		National Federation President (not in coach chair)	Delegation areas including Field of Play VIP areas and tribune
		Physiotherapist	Delegation NOT Field of Play
		Judoka	
		Local organiser (Not FOP)	

		<p>TV Host Broadcaster</p>	<p>TV areas including Field of Play</p>
		<p>Photographer</p>	<p>Photo areas including Field of Play</p>
		<p>TV</p>	<p>Media areas NOT Field of Play</p>
		<p>Written Press</p>	
	<p>-</p>	<p>VVIP Executive Committee with photo and name</p>	<p>All areas</p>
	<p>-</p>	<p>VVIP</p>	<p>VVIP areas and tribune and FOP For use alone or as an upgrade card to large accreditations</p>
	<p>-</p>	<p>VIP</p>	<p>VIP areas and tribune not FOP For use alone or as an upgrade card to large accreditations</p>
		<p>Local organiser VIP</p>	<p>Local VIP areas and tribune</p>

		<p>Local organiser and EJU guest</p>	<p>Delegation tribune/ non-ticketed spectator tribune</p>
---	---	--------------------------------------	---

11. Draw

11.1 Procedure and timing

The draw will take place before the first day of contests after the accreditation. Times for the draw:

<p><i>European Judo Cups</i> (cadet, junior, senior)</p>	<p>Day before event 19:00</p>
<p><i>European Judo Open</i></p>	
<p><i>European Judo Championships</i> (cadet, junior)</p>	<p>Day before event 16:00</p>
<p><i>European Judo U23 Championships</i></p>	<p>Day before event 16:00</p>
<p><i>European Judo Championships Seniors</i></p>	<p>Day before event 16:00</p>

Before the draw the lists of each category are hung in the corridor outside the draw room or published in the Telegram Channel. Each Head of Delegation is responsible to check that all inscribed competitors are on these lists and that they are under the right category and with the correct IJF World Ranking List position. No corrections can be made after the draw.

At least one delegate from each participating National Federation must attend the draw. After the completion of the draw, two sets of the draw lists will be provided to each delegation.

Dress code: Jacket suit with tie.

In case of special circumstances, Online DRAW will be held.

11.2 Seeding

Athletes will be seeded based on their position of the respective ranking list.

	Number of athletes seeded	Ranking list
<i>European Judo Cup Cadets</i>	8	IJF Cadet World Ranking
<i>European Judo Cup Juniors</i>	8	IJF Junior World Ranking
<i>European Judo Cup Seniors</i>	4	EJU Senior Ranking
<i>European Judo Open</i>	8	IJF World Ranking
<i>European Judo Championships Cadets</i>	8	IJF Cadet World Ranking
<i>European Judo Championships Juniors</i>	8	IJF Junior World Ranking
<i>European Judo U23 Championships</i>	8	IJF World Ranking & EJU Senior Ranking *
<i>European Judo Championships Seniors</i>	8	IJF World Ranking
<p>* Seeding at U23 European Judo Championships:</p> <ul style="list-style-type: none"> • 4 top athletes from places 1 - 80 in the IJF WRL to seeding positions 1 to 4 • 4 top athletes from the EJU Senior RL to seeding positions 5 to 8 <p>In case there will be less than 4 athletes inscribed from places 1 - 80 from the IJF WRL the additional athletes from the EJU Senior RL will be moved up the seeding positions until 8 athletes are seeded.</p>		

For the rest of the draw separation by nations will be respected. However, seeding position will take priority over separation by nation in categories where there are lower numbers. If necessary, the EJU Sport Commission will agree the seeding rules for other events.

11.3 Facilities and technical requirements

The draw room must have enough seats for 2 delegates per participating federation plus enough seats for EJU officials, referees and media. For Senior European Championships the minimum capacity is 180, for all other European Championships 150. The draw room must be ready latest 4 hours before the draw.

Technical equipment must be provided according to EJU IT Handbook. A technician must be at disposal during the preparation and during the draw.

Dress code: formal

The banners, deco fabric etc. must be according to EJU Marketing rules and design guidelines. ALL MATERIALS MUST BE APPROVED BY EJU.

Additionally, please refer to IT Requirements - Draw.

11.3.1 Requirements for European Judo Cups:

- One big projector with audio connection in centre
- Two tables for three officials on sides of projector, spider behind each table
- Name cards on tables
- Audio equipment with microphones on each table and two to three roving microphones
- The key person from organizer must assist the draw for any possible questions concerning any subject related with domestic issues
- Internet
- Cabling must be tidied and covered

11.3.2 Requirements for European Judo Open & European Judo Championships:

In addition to the above mentioned requirements for European Judo Cups:

- Plasma screens facing officials with signal from Computers
- Real-time switcher between two computer feeds for projector (see EJU IT handbook)
- Lighting control must be available to dim during presentation and bright during speech as well as spots on organizer
- Speaker rostrum and microphone for the presenter
- Small bottles of mineral / natural water and glasses for persons on the main table
- Draw speeches - three minutes maximum and not longer than the Presidents if he is in attendance
- Welcome cocktail should take place after the Draw. This should be a standing reception offering drinks and snacks. All EJU and delegation representatives, VIPs, referees and guests attending the draw are invited to this cocktail. Menu should be sent to the Presidential office for approval.

Not compulsory, but recommended:

- VVIP “celebrity” guest arranged by organizer is welcomed/recommended to attract media

12. Weigh-in

12.1 General regulations

The weight control can take place in the competition venue or in the official hotels allocated by organizers for participating delegations. Locations for weight control have to be approved by EJU Sport Delegate.

Organizers should provide separate rooms for men and women (approx. 100m² each) and enough calibrated electronic scales showing only one decimal place i.e. 51.9 kg, 154.6 kg (two per room and one scale in reserve for each room). If more than one scale is being used at that location, then the weight category to be controlled should be posted in front of it. The scales should be placed on a solid floor that is not carpeted.

Further equipment for each weigh-in room:

- One (1) table, two (2) chairs per each scale
- Separation tapes or material to streamline access of athletes (lines) to the scales
- Two (2) weigh-in lists per weight category
- Writing materials

The official weigh-in will be organized the day before the competition at 18:30. If for any reason a different time is proposed it shall be agreed by the EJU Sport Delegate.

For team competitions, the weigh-in is organized one day before the competition. There will be a +5% tolerance for athletes who competed in the Individual Championships and NO tolerance for athletes who are only inscribed for the team competition.

The official weigh-in control period shall be between 30 - 60 minutes.

At least one set of test scales should be available (from the arrival of the first delegation) in all official hotels between 08:00 - 22:00 for athletes to check their weight.

Athletes shall be allowed to check their weight on the official weigh-in scales (that will be used for the official weigh-in) from 60 to 30 min before the official weigh-in commences. There is no limit to the number of times each athlete may check his weight during the time of the unofficial weigh in.

In the cadets age category athletes are NOT allowed to remove their underclothing (boys - underpants, girls - underpants and bra) to compensate an additional 200 grams will be allowed i.e. for the category 44 kg the limit will be 44.2 kg.

12.2 Official Weigh-in Procedure

The Organizers shall make available a minimum of two national referees/officials per each official scale. One to check the passport and weight of the athlete and one to record the exact weight on the official weigh in list. An additional official/volunteer should also be available to control the flow of athletes. To protect the privacy of the athletes, officials supervising the weigh-in must be of the same gender as the athletes. The EJU IT team in charge of the event shall make available one copy of the weigh-in list for each weight category for the organizer and one copy for the EJU Sport Delegate(s) conducting the weigh-in before the scheduled start of the official weigh-in period.

Photography or filming is not permitted in the weigh-in area. This includes the use of mobile phones and all other devices. All coaches and other team delegates must leave the weigh-in room before the start of the official weigh-in.

The athlete is allowed to stand on the scales only once during the official weigh-in period.

Each athlete shall bring to the weigh-in their EJU accreditation card issued for the Championships and their passport or an official identification document with photo. The athlete shall present both documents to the official, who will verify the identity of the athlete.

The official then invites the athlete to stand on the scales. The athlete shall weigh-in wearing only underclothing (men/boys - underpants, women/girls - underpants and bra). Any socks, jewellery or body piercings must be removed. The athletes are allowed to remove their underclothing - without stepping off the scales - to ensure they reach the minimum or the maximum weight limit of the weight category in which they are entered.

The official supervising the weigh-in shall note and record the athlete's weight in kilograms (accurate to one decimal point of a kilogram).

The athlete steps off the scales.

Failure to appear for weigh-in control: Should an athlete fail to appear for weigh-in during the official weigh-in period, this shall be noted beside his name on the official weigh-in list. A weigh-in official and the EJU Sport Delegate shall sign the notation. The athlete will be excluded from competing in that weight category.

Failure to weigh-in within the prescribed limits of a category: Should an athlete weigh either above or below the prescribed limits for the category in which he is entered the exact weight shall be recorded in the normal manner. The weight shall be circled and signed by a weigh-in official, and a member of the EJU Sport Delegate and by the athlete himself or a member of his delegation. The athlete shall be excluded from competing in that weight category.

Failure to comply with official directions or with requirements of the IJF SOR: If at any stage during the weigh-in period, an athlete fails to comply with the directions of any weigh-in official or an EJU delegate, or fails to comply with the requirements of the IJF SOR, the athlete shall be prevented from participating in the weigh-in and the nature of the infraction brought immediately to the attention of the EJU Sport Delegate.

Anyone not passing the official weigh-in (through not appearing, failing the weight or failing to comply with official directions) will be removed from the competition and the revised draw sheet will be posted on the official notice board in the warm up area. Their original opponent will pass to the next round and this will be considered their first contest.

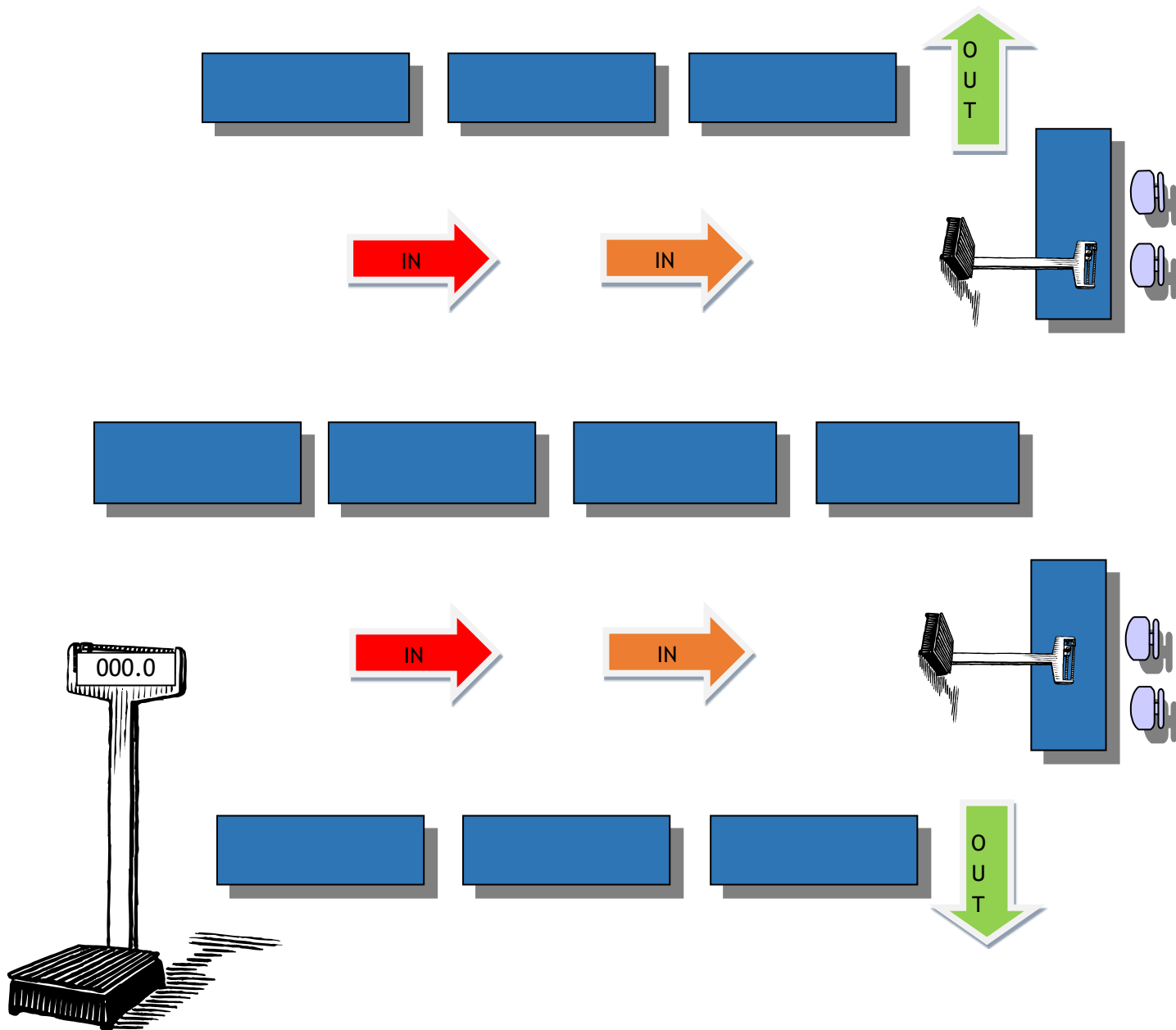

12.3 Random weigh-in

The random weigh-in is the responsibility of the EJU Sport Commission. Random weight checks for cadets, junior and senior athletes may be organised before the first contests on each day. If the competition has different starting blocks scheduled, then the relevant random weigh-in times can also be different. The random weigh-in takes place one hour before the start of the competition each day. The time limit to arrive to the random weigh-in is 30 minutes or 6 contests before the athlete's first contest at the latest.

The rules will be the same as those of the official weigh-in with the exception that the athletes do not need to bring their passports, as their accreditation is sufficient for identification. The weight of the athlete cannot be more than 5 % higher than the official maximum weight limit of the category. The drawn athletes will be given only one chance for an unofficial weigh in. There will be no random weigh-in for EJU Mixed Team and Team events.

12.4 Random Weigh-in Procedure

Draw of the athletes: The responsible EJU Sport Delegate will perform the draw of the athletes by means of software on a laptop, one (1) hour before the start of the preliminaries of the competition each day. This will be done at the place of the EJU IT person running the competition. Four athletes per category (except those that are plus categories) will be drawn.

Random Weigh-in time: For EJU events the random weigh-in will open one hour before the start of the competition each day. The time limit to arrive to the random weigh-in is 30 minutes or 6 contests before the athlete's first contest at the latest. The athletes must bring their accreditation for identification. The weight of the athlete cannot be more than 5 % higher than the official maximum weight limit of the category.

Collecting the athlete: The list of named athletes drawn for the random weigh-in will be officially posted on the official noticeboard placed near the warm up area.

Weigh-in procedure: Four volunteers (two men and two women) will operate the weigh-in. Two volunteers will identify the athletes and the two others will proceed with the weigh-in in two separate private rooms, one hour (1) before the start of the preliminaries each day. Test scales should be available for the duration of the weigh-in so that the athletes can test their weight before they chose to go to the official weigh-in.

After weigh-in procedure: If an athlete's weight is 5 % higher than the official maximum weight limit of the category the EJU Sport Delegate should be immediately informed and the overweight athlete will be excluded from the competition. The opponent of the overweight athlete should go on the mat and bow (they will be declared the winner by fusen gachi).

Anyone not passing the random weigh-in (through not appearing, failing the weight or failing to comply with official directions) will not be allowed to take part and their opponents will report to judogi control and go onto the tatami where they will be declared the winner by fusen gachi.

13. Competition Venue

13.1 Venue

The competition venue should be large enough to host the event. For the Senior European Judo Championships and European Games the seating capacity should be a minimum of 5,000. The venue should be well lit and of a constant temperature of between 18 - 22°C. More information for event organizers can be found in the IJF EOG.

The venue must be safe and free from any trip hazards. All debris from the installation must be removed and cables should be tidy, taped down and covered. The venue must have directional signage to assist with the flows of the client groups and security. All areas must be cleaned regularly to an acceptable hygienic standard. The toilets and changing areas should be checked regularly during the event and soap, toilet paper and hand towels replenished.

13.2 Training Venue

The Organizing Committee shall provide training areas and transport for all delegations. The training areas should be sufficient to accommodate the number of participants; it should be adequately ventilated and a temperature of 18 - 22°C maintained. Tatami used in the training venue should be approved by the EJU Sport Commission. The minimum height above the mats must be 5 m.

During European Championships training areas for two days before the start of competition should be provided that are separate from the warm up area. Ancillary facilities should include showers, sauna, scales and medical provision.

Training times should be coordinated between the Organizing Committee and the delegations.

13.3 Warm Up Area and Judogi Control

Warm Up Area and Judogi Control are the joint responsibility of the EJU Sport and Marketing Commissions.

The warm up area must have the same rules as a dojo. Television cameras may film there so it should be kept tidy with NOTHING on the tatami except the competing athletes warming up. For other activities (eating, resting etc.) alternative spaces will be used. It is a shared space for all athletes to use. Delegations should not guard a space for their team.

If there is no other training venue those athletes competing the next day can train two (2) hours after the start of the competition.

Coaches are responsible for their delegation and must educate their athletes. If a delegation does not follow the rules ALL coaches from that delegation will have their accreditation removed for that day and if found coaching from the tribune will be subject to a disciplinary sanction.

There must be a warming up area(s) the size of which will be agreed by the EJU Sport Commission. Tatami used in the warm up area should respect the IJF tatami Sport and Organisation Rules of the International Judo Federation page - 61 rules (see 8.6). The tatami need to be placed on a resilient floor at ground level. If the floor is concrete, there should be Taraflex (or similar) underneath the mats. The minimum height above the mats must be 5 m. The main purpose of the tatami is for the athletes competing that day to warm up and there will be a strict respect on the tatami policy. The EJU Sport Commission will restrict warm up area access to those athletes that are competing that day. If there are no other training venue(s) then non-competing athletes will not be allowed to access the warm up area until two (2) hours after the start of the competition.

Screens showing the contest order and live contests should be available in both the warm up area and the judogi control areas so that coaches and athletes can always follow the competition.

A notice board should be placed in or near the warm up area so that information for the delegations can be displayed.

During the preliminaries, for the first contest, athletes and their coaches must arrive together at judogi control 15 minutes before the contest. For the following contests, athletes and their coaches must arrive together at least three (3) contests before their own (not counting the contest in progress).

See: SOR C1.1.3 Consequences of Failing Judogi Control

For the next rounds athletes must pass judogi control and be on time for their contests. If they do not arrive on time the 30 second rule will be applied (see Appendix D, Article 19). Athletes arriving during the 30 second countdown will not be allowed to have their coach accompany them onto field of play.

If any athlete is not able to continue in the competition the Sport Director must be informed immediately. The EJU Medical Commission delegate will verify the withdrawal if it is due to a medical reason.

Athlete Seating and Facilities: The athlete tribune, changing rooms, toilets and other facilities etc. should be as close as possible to the warm up area.

For judogi control an area of at least 150m² is required. The area should be ready until rehearsal at 17.00h before the start of the competition for inspection by the EJU. The reserve judogi with the different sizes and belts should be made available at this time.

Required equipment and staff:

- 2 National referees per tatami plus one supervisor and 2 referees responsible for releasing the athletes
- 3 tables per tatami
- 4 chairs per tatami
- Four (4) Sokuteiki
- Four ultra violet lamps to check authenticity of IJF optical labels
- Hanging systems for reserve judogis and 20 hangers
- One booth (a closed space) serving as changing area
- 2 small tables and 2 chairs (for EJU supervisors)
- 20 pieces of reserve Judogi (10 white, 10 blue) - see EJU Marketing Rules
- Large screens showing contest order
- A sound system is required. Each table should have one wireless microphone. There should be a loud speaker in the warm up area to allow the athletes to hear their names.
- Four volunteers with four (4) Walkie talkies to organize communication between warm up area and call room to assist with athletes' check in
- A sewing service in the sport hall operating during the competition days close to the judogi control area
- 8 volunteers per tatami with baskets, escorting athletes with their belongings (must be trained to be professional and be able to control the Judoka and need to be dressed in the competition clothing. The boxes must be decorated on the outside to look nice with competition logos.)
- Enough of "Airport barriers" depending on the number of tatamis

Reserve Judogis

The organiser has to provide reserve Judogis, which are borrowed to athletes in case of rupture, cut, stains from bleeding and similar reasons for which an athlete cannot continue fighting in his own Judogi.

The min. number of each white and blue Judogis:

150 1x, 155 1x, 160 1x, 165 1x, 170 1x, 175 1x, 180 1x, 185 1x, 190 1x, 200 1x

Reserve Judogis have to be ordered from **EJU Supplier**.

For European Championships: Premium Supplier is obligatory (EJU will inform in due time).

13.4 Entry to Field of Play

The venue speaker(s) announce the players as they enter the FOP and the result of the contest. If athlete entry is from the left the first athlete called is the one in the blue judogi followed by white. If it is from the right the first athlete called is the one in the white judogi followed by blue.

Athletes must enter and leave the FOP wearing their judogi in the proper way. It is not allowed to remove any part of the judogi or the belt until the athlete has left both the FOP and the Media Mixed Zone.

Religious, political, personal or commercial connotation is prohibited for everyone on the FOP.

Entry of the Field of play is required to have sponsor back wall (minimum 5x3m) or black fabric according to the EJU Marketing Guidelines.

13.5 Field of Play and Competition Area

A minimum of three entrances to the FOP are needed to run the competition and if there are less than this it has to be approved by the EJU Sport Commission.

The competition area shall be divided into two zones: the contest area and the safety area and each shall be a different colour with sufficient contrast to avoid misleading edge situations. The EJU Sport Commission must agree the number of contest areas required.

The contest area for EJU events shall be a minimum of 7 m x 7 m and a maximum of 10m x 10m, the recommended size is 8 m x 8 m. The minimum sizes for the various event types can be found in the table below. The safety area shall be a minimum of 3m. Where two or more adjoining contest areas are used, a common safe zone may be used to satisfy the minimum distance of 4m between them.

A free zone of 50cm minimum must be maintained around the entire competition area.

	Minimum size of competition area
European Judo Cups (cadet, junior, senior)	7m x 7m, 4 m between contest areas, 3 m around
European Judo Open	8m x 8m, 4 m between contest areas, 3 m around
European Judo Championships (cadet, junior, U23)	8m x 8m, 4 m between contest areas, 3 m around
European Judo Championships Seniors	8m x 8m, 4 m between contest areas, 4 m around or 10m x 10m, 4 between contest areas, 4m around

The number of tatami for particular events is set by the EJU Sport Commission.

The contest areas are numbered from left to right from the side where the technical table is located.

The tatami need to be placed on a resilient floor at ground level. The elements making up the surface must be aligned without space in between; the surface must be smooth and fixed in such a way that the individual mats cannot be displaced. If the floor is concrete, there should be Taraflex (or similar) underneath the mats. The minimum height above the mats must be 5m.

All tatami for EJU events (competition & training camps) must be of IJF Standard approved by EJU.

The official colours are yellow (123C) for the contest area and red (1795C) or EJU blue for the safety area. Any other colours proposed by the Local Organizing Committee must be approved by the EJU before use. Each mat should measure 1m x 2m x 5 cm and be made of pressed foam. They must be firm under foot, have the property of absorbing shock during ukemi, and not be slippery or too rough.

Until December 2022 existing tatami can be used, but from 1. January 2023 no exception can be made.

Any decoration on the tatami, such as the host city name, year or event logos, can only be placed on the safety area never on the contest area.

City name and year has to be stucked two times on the safety zone of each tatami (no longer than contest area, 1 m high, font according to EJU design guidelines). During final blocks, the other tatami must be covered so that the main tatami is accentuated.

13.6 Security

The LOC is responsible for the safety of all participants and guests. Security must be positioned to validate accredited personnel access. The security strategy must be approved by the EJU. The LOC must set the access plan for the stadium and send to the EJU for validation. Appropriate measures are to be taken prior to, during and after the event to ensure public safety.

These measures include:

- Providing safety on the grounds of all official hotels, venues and neighbouring areas, which spectators and participants will make use of during the event
- Entrance control, CCTV
- Restriction of intoxicated people, with alcohol or drugs, or visibly unstable persons from entering the venue. No tolerance regarding alcohol consumption within the sport venues
- Spectator inspection (weapons, fireworks, alcohol, glass, laser devices)
- Evacuation plan of the venue duly approved by local authorities (i.e. police, fire department, emergency response)
- Expedite investigation and action regarding any illegal action. Establishing counter-terrorism measures and immediate response to any legal violation
- Hotels, rooms or transportation of participants should not be marked with their national flags to best prevent any undesirable activities
- Security staff must be familiar with the EJU accreditation symbols

In order to run a professional event the Field of Play (FOP) must be kept clear. If someone does not have a role on the FOP or their job has finished they should not be there. They should move to the spectator tribunes of the back of house to watch the competition.

13.7 Rehearsal

One of the most important part before the start of the all European Championships that should be taken very seriously is rehearsal which is scheduled for 17.00h day before the event. At exact time LOC should be ready to have test event on one tatami. The team should consist of scoreboard operator, CARE system or Fair Replay camera operators (*TV Team if senior level), people to simulate the contest (white & blue judoka + referee), awarding ceremony team, local stadium announcer, stadium technician (sound & light).

13.8 Lighting

The venue light or lighting rig should be minimum 1500 LUX on tatami and should be consistent. This means that it should be 1500 LUX covering all tatamis and entire safety area and one metre beyond the safety area.

13.9 Cleaning & Officials table

All spaces in venue should be properly cleaned after installations are done, prior to the start of competition and during if needed. They should also be cleaned after the activities of each day. All toilets should have adequate stocks of toilet paper, soap and hand drying facilities, which should be regularly replenished.

First row of the officials' podium should be 40cm high, second row should be 80cm high. Minimum of two gaps entry from the front side should be created, as well as at least one side entry.

Tables for the officials should have plenty of working space, ideally 80cm x 120cm/per piece, which should accommodate two officials without being stuck between table "legs".

Tables and podium should be decorated according to EJU Marketing guidelines.

14. Transportation

The Organiser must make available means of transportation to facilitate the arrivals and departures of the officials and participants between the station or the airport and the place of accommodation, and also between the competition venue and training sites and the place of accommodation. These transportation arrangements are only made available to participants who have been accredited. Waiting time at the airport for delegates should not exceed 30 minutes.

14.1 President

A chauffeur-driven car has to be dedicated to the President, from his time of arrival till his time of departure. The model of the car has to be confirmed with the Presidential Office. Closer to date, the name and telephone number of the driver (non-smoking and fluent in English) should be communicated to the Presidential Office.

14.2 EJU Delegates (Executive Members, Commissioners, Staff)

The number of mini vans and cars has to be agreed in advance with EJU Head Office. This number depends on the number of EJU Delegates and the distances between all venues. It should be taken into consideration that especially during preparation days, minivans and cars dedicated to EJU Delegates should not be used for airport transfers of participants.

On spot, a volunteer should be dedicated to coordinate mini vans and cars for EJU Delegates in close collaboration with EJU Head Office.

14.3 VIPs

see VIP Handbook

14.4 Referees

The referees should have dedicated transport to and from the venue. A transport schedule should be distributed to all referees. Referees should arrive at the competition hall one hour before the start of competition.

14.5 Athletes and Coaches

A shuttle service should be provided for athletes and coaches (booked through the organising committee) from the official hotels to the sports complex and vice-versa. This service should have a set time-table which should be displayed in all official hotels and the competition venue.

If the locations are not within walking distance (not more than 5 minutes on foot), transport has to be provided accordingly. In all cases, backup transport has to be provided for emergency situations like injured athletes, coaches or referees with mobility problems, or weather conditions such as heavy rain.

- For accreditation
 - o A shuttle service should be provided every hour.
- For the draw
 - o Transport has to be provided so that the delegates arrive at the draw room not later than 15 minutes before the start of the draw.
- On competition days:
 - o The first bus in the morning must be scheduled so that athletes arrive at the venue 90 minutes before the start of the competition. Until start of competition, the intervals have to be 30 mins, after the start of competition, intervals can be 60 mins. The journey time from the hotel to the sports hall should be clearly defined on the transport information schedule, which should be displayed in each hotel and the sports hall.
 - o Round trip from the hall to the official hotels and back every 1-1,5 hours. At the end of medal ceremony and every half an hour after that, until 1,5 hour from the end.
- Anti-Doping control:
 - o A car has to be provided to take the EJU Doctor back to the hotel.
 - o Cars, Minivans and / or buses should be available to take the athletes and accompanying officials after the anti-doping control from the sports hall to the hotels.

15. Marketing

15.1 Basic principles

The branding of the whole event must be in line with EJU Corporate Image. Main color for decoration is EJU BLUE - Pantone Solid C (C100 M50 Y0 K0).



For EC: The event logo, the event mascot, all decoration and graphical elements like posters, billboards, etc. and the layout of the event website have to be sent before production to EJU for approval.



In all decoration layouts the principle 50/50 should be followed, which means wherever the local sponsor logos appear - EJU sponsor logos should also appear in the equal quantity.

All Marketing Materials need to be ordered from EJU except for several exceptions which are specified in next paragraphs.

All materials must be very good stretched, without waves, clean.

15.2 Competition Venue Dressing

The competition venue should be decorated with the look of the event in the agreed colour scheme according to EJU Marketing rules and EJU design guidelines.

Advertising banners need to be placed throughout the sports hall and include event logo, EJU logo, organizer logo, sponsors, name of the competition. Flowers can be included to add life to the stadium.

Entrance tops should also include the competition logos, sponsor logos and EJU/Organizer logos.

Important: All design elements and graphics have to be approved by EJU before printing!

15.3 Decoration of Official & Technical tables

The tables on the officials' podium in the venue, on the stage of the press centre and at the draw must be covered with the official EJU deco fabric (blue with EJU logo on the front side and yellow on top of the table). Fabrics should be ordered by EJU.

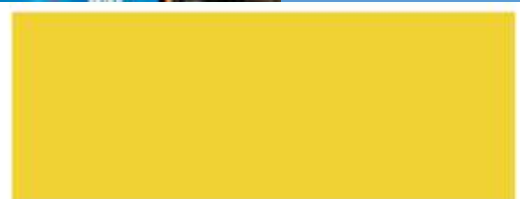
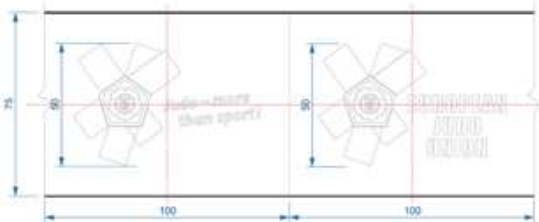

Small 15 cm high privacy screens can be built in front of the table to hide computers, equipment and paperwork etc.

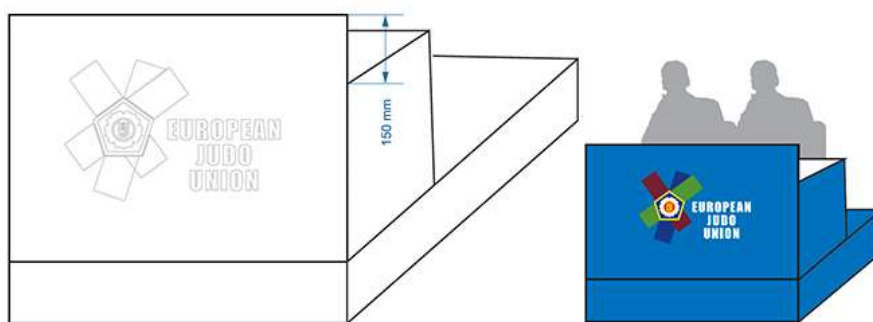

Table dimension: all types of tables need to provide 80 cm for each person, and maximum depth is 80 cm. Space of 120 cm is needed behind tables. Tables need to be stable and of good quality. Length of tables in total depends on number of tatamis.

15.4 Printed sponsor boards

The organizer has to provide printed sponsor boards on 2 short sides of the tatami (in case LED boards are used for the long side) or on 3 sides of the tatami (if LED boards are not used). The standard size

of the printed boards is 80cm x 150 cm. In case the LED boards are used the height of the boards should correspond the height of the LED.

For European Opens and European Championships using LED boards is obligatory.

- The allocation of logos on these boards, which will be moved for the final block towards the two inner mats, have to be shared equally between the organizer and EJU.
- The printed boards must not be printed on glossy material.

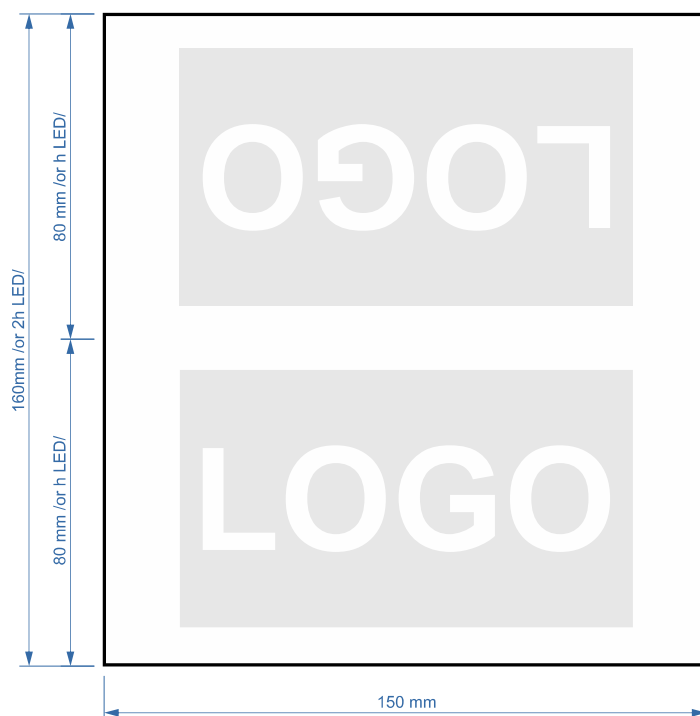

The design of the boards is as shown above.

15.5 Coach Boxes

At each mat there must be two coach boxes used.

Specifications:

- Placement behind LED or between sponsor boards.
- One blue and one white with EJU logo.
- Writing table for coach inside this box.
- Fixed chairs if possible.
- In case the LEDs are used the coach box has to be placed on 20 cm platform.

TWO OPTIONS

- With LED sponsor board. In this case Coach box is behind LED and placed on 20 cm platform.

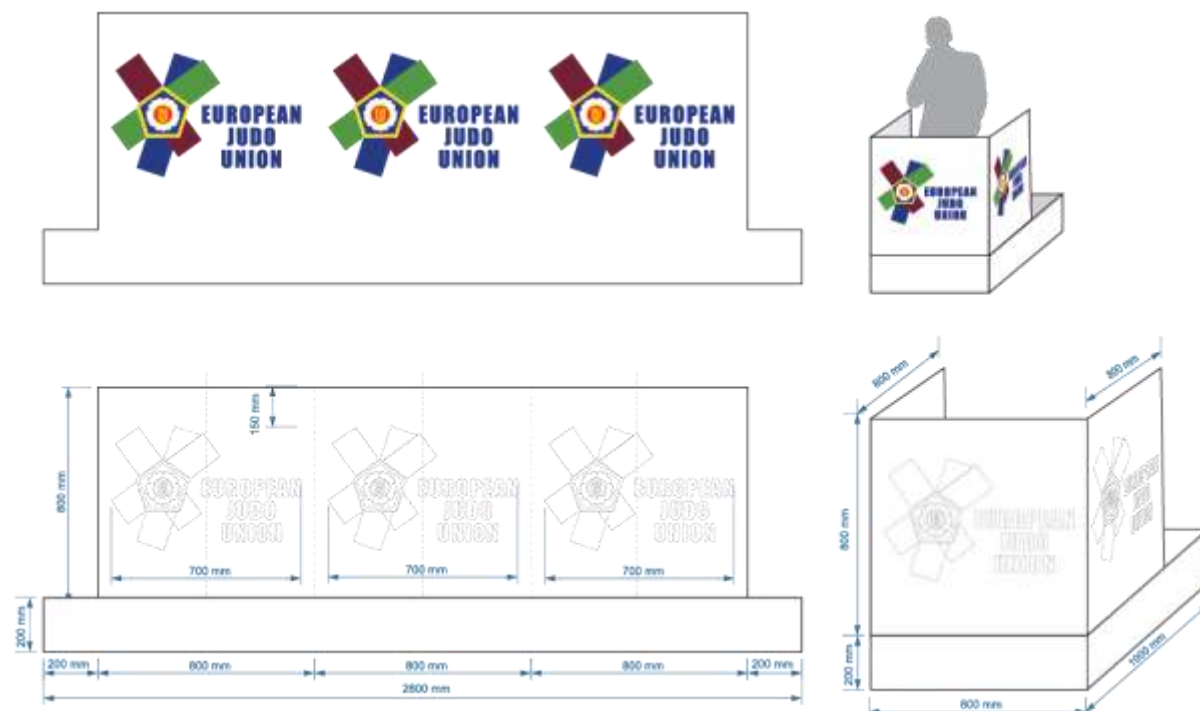

- With Printed sponsor boards. In this case Printed sponsor boards are by side of Coach box.

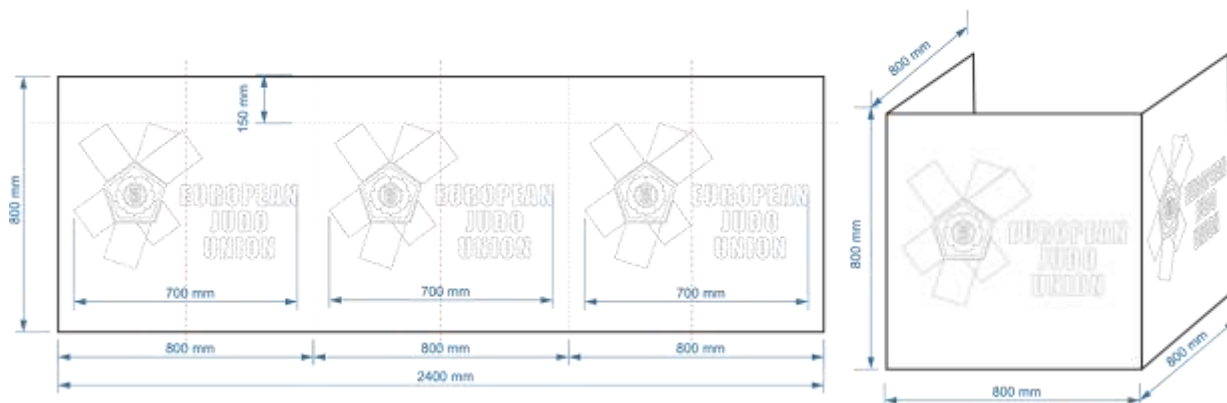

IMPORTANT: is to have setup nice in row without space between them

15.6 Roll-up banners and Deco Flags

- The EJU logo should be well displayed in the venue and all related side-venues (draw, etc). Here are the correct logo variants

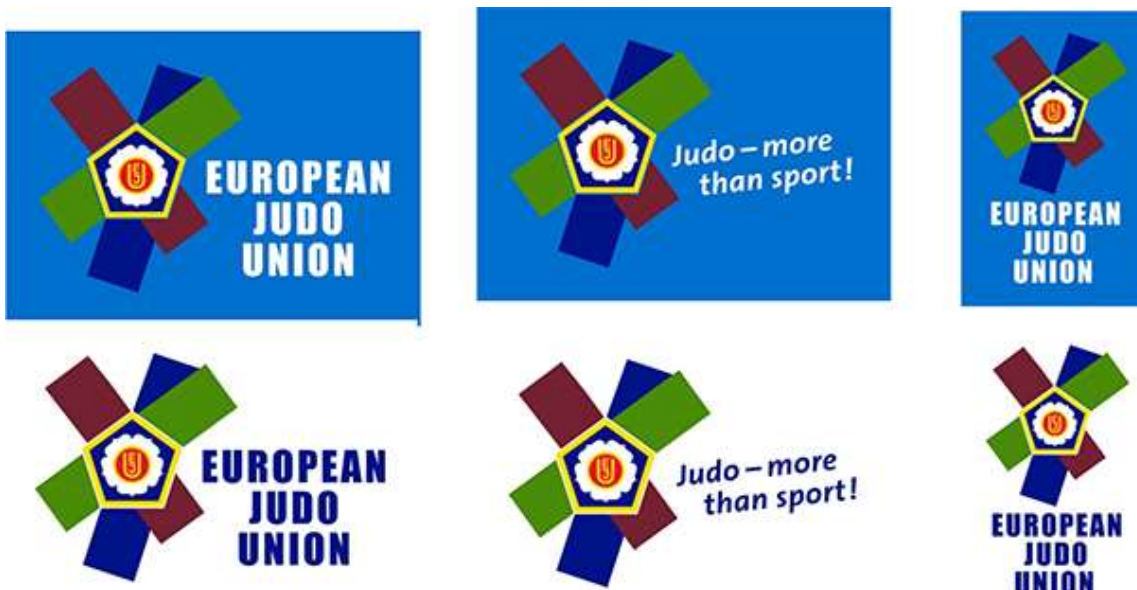

- The organizer should have enough roll-up banners, flags in standard EJU design.



EJU Flag Deco (150 x 400)
 Obligatory number
 European Cups: 2
 European Open: 4
 European Championships: 4



EJU Flag official (150 x 220)
To be placed with National
Flags of participating
countries
Obligatory number: 1



Roll-up EJU standard
Obligatory number
European Cups: min. 6 (2 per hotel,
4 in the venue)
European Open: min. 8 (2 per
hotel, 6 in the venue)
European Championships: min. 12
(2 per hotel, 8 in the venue)

EJU Roll-Ups and Flags should be ordered by EJU.

15.7 Direction System

- All venues must have sufficient number of signs marking the various rooms or zones and helping the delegates finding the way. The design of the signs will be submitted by EJU.
- Need to include: EJU / Organizer (Event) logo. Sponsor Logos and directions
- The signs should be in English (can be doubled in local language)
- The necessary number of direction signs have to be printed out on A4 paper, laminated and displayed in the evening before the event. The design layout should be requested by EJU.



15.8 Tatami Stickers (should be used at European Opens and European Championships)

- The stickers on the tatami with the City and year may be used.
- The stickers are placed 1 m from the tatami edge (in the safety zone). Placed 1m from yellow field. Direction: always both sides to be readable for main camera (official table).
- Font: Trebuchet.
- 1 m high, the name should be readable from the official/photographers' side.
- LOC should have enough backup tatami stickers in case some of them damage during competition.

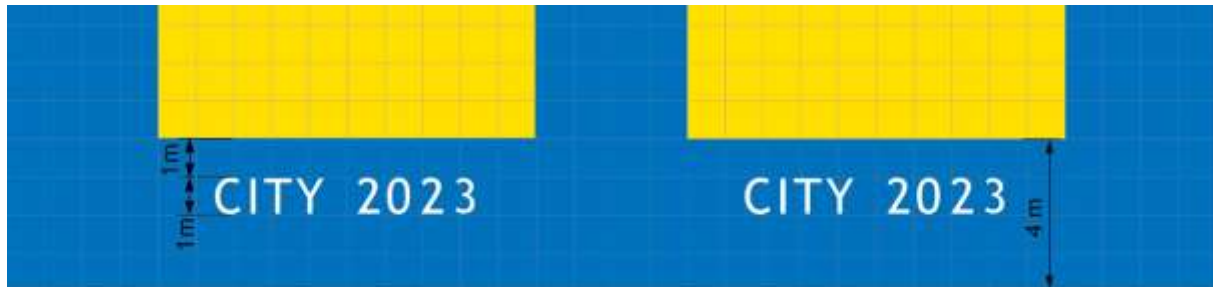

15.9 LED Boards

For European Judo Championships and European Opens the organiser has to install LED boards along the long side of the mat. The LED boards should be 1 m high; the length depends upon the sizes of the tatami and the safety zone and should be calculated in such a way that they include integrated scoreboard (1,5-2 m) and the sponsor part and the gap between the LED boards is 1 m for the athletes flow to/from the tatami. Distance from tatami - 1 m. The sponsors on the LED boards should be displayed with an interval of 15-20 seconds. The time must be equally shared between EJU and Organiser, which means a local sponsor is followed by EJU sponsor, which then is followed by local sponsor and so forth. All animations have to be sent to EJU for approval.

The backside of the LED boards has to be covered by deco fabric (printed or black).

- Minimum Pitch is 6.2
- We use for European Championship
- We recommended for European Opens
- Cups, Veterans: it is not obligation

DIMENSIONS:

Option 1



- Tatamis 8X8 + 4 m security zone;
- Middle LED screen is 14m, left and right screens are 11m;
- Scoreboard is integrated into the LED;

- Gaps between screens are 1m.

Option 2



- 3 tatamis; 10X10 + 4 m security zone;
- Middle LED screen is 16m, Left and Right screens are 13 m;
- Scoreboard is integrated into the LED;
- Gaps between screens are 1m.

15.10. MEDAL WALL and AWARDING PODIUM

The share rule of 50% for Organizer and 50% for EJU needs to be followed on the medal wall regardless of total number of sponsors.

Elements

1. City, Competition name, Year, (e.g. Oberwart European Open 2023).
2. EJU logo (left upper corner) + local federation/event logo (right upper corner).
3. Sponsor logos on the banner. Size of each sponsor box should be according to EJU layouts.



The layout for the medal wall is done by EJU designer and then printed locally. The organiser has to provide the local sponsor logos to EJU Head office well in time (at least 2 weeks before the event) and in the correct format.

The requirements to the sponsor logos: *.eps, *.ai, *.pdf from vector formats

- all objects without included bitmap images;
- all objects - in CMYK color mode;
- all objects must be on artboard only;
- texts in curves.

The medal wall and the podium standards are different for different types of the competitions. The medal wall sizes described are the MINIMUM requirements.

The final sizes will depend on the layout and sizes of the venue and will be approved by the EJU. **EUROPEAN CUPS**



- Medal wall dimension is 6x3 m
- Awarding podium length is: 1st place - 1m, 2nd place - 1m, 3rd place - 2m
- Awarding podium height is: 1st place - 40cm, 2nd place - 30cm, 3rd place - 20cm

EUROPEAN OPENS



- Medal wall dimension is MINIMUM 10x4
- Awarding podium length is: 1st place - 2m, 2nd place - 2 m, 3rd place - 4m
- Awarding podium height is: 1st place - 40cm, 2nd place - 30cm, 3rd place - 20cm

EUROPEAN CHAMPIONSHIPS

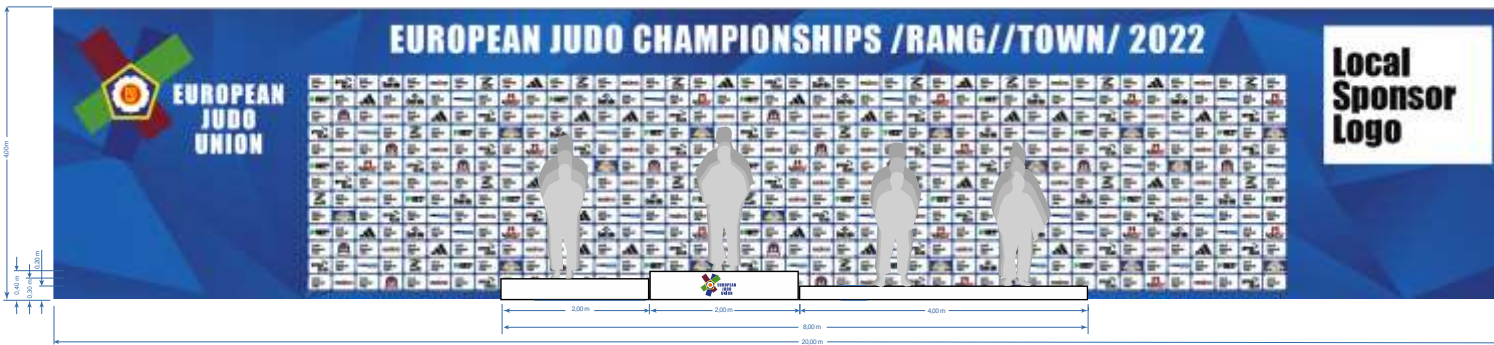

- Medal wall dimension is MINIMUM 20x4
- Awarding podium is: 1st place - 2m, 2nd place - 2m, 3rd place - 4m
- Awarding podium is: 1st place - 40 cm, 2nd place - 30cm, 3rd place - 20cm
- Awarding podium length for teams: 1st place - 4 m; 2nd place - 4 m; 3rd places - 8 m

15.11 Medals

The medals for all events except of Veteran EC are designed and produced by EJU.



15.12 Trophies

For events when the team competitions are held the organiser has to produce the trophies, in other events on the decision of the organiser. The designs are done locally and then have to be sent to EJU for approval.

Some general rules to follow

- Recommended minimum size of the trophy;
- 1st place-47cm;2nd place42cm and 3rd place-38cm
- Inscription on the trophy:

Junior European Judo Championships
Malaga 2016 - Spain
1. Place
Team Men



15.13 Sponsor stickers for back numbers are obligatory for all events except Veterans Championships

All participants are obliged to have the official EJU/IJF backnumbers on their Judogis. The space on the backnumber of white judogi belongs to EJU and of blue judogi belongs to the Organiser. If the Organiser does not want to use the space on the backnumber, also the space on the blue judogi is used by EJU. The organiser must confirm well in advance, whether the space will be used. The EJU reserves the right to keep the space on the backnumbers empty.

There can only be one sponsor on a backnumber. The Organiser can sell its backnumber space for own profit. All sponsor stickers to be placed on the backnumber (for white and for blue Judogi) must be ordered by the Organiser from the official EJU Partner via EJU order form as Annex to the Contract at cost of the Organisers. The logo of the domestic sponsor must be available at latest 6 weeks before date of the competition



15.14 Reserve Judogis and Event backnumbers

The Organiser must ensure that the reserve Judogi, provided by EJU, are available in the contest area, satisfying all technical and marketing criteria. Only Reserve Judogis provided by EJU can be used. The minimum number of white Judogis: 150 1x, 155 1x, 160 1x, 165 1x, 170 1x, 175 1x, 180 1x, 185 1x, 190 1x, 200 1x and exactly the same number in blue.

On all reserve Judogis the event backnumber has to be sewn (provided by EJU).

15.15 Dress code volunteers

Volunteers like the ones carrying the baskets with the belongings have to wear uniform T-shirts or Poloshirts with the EJU logo on the left chest and the word “ORGANIZATION TEAM “ or “ORGANIZATION” or “TEAM” on the back.

T-Shirts could be ordered from EJU Directly.

15.16 Vests for photographer & medical team

Photographers must receive a photographer vest with PHOTO on the back (navy blue or black) and medical staff should wear white vests with MEDICAL TEAM on the back. Staff of the host broadcaster should wear vests with TV on the back.

Vests should be ordered from EJU Directly.

Obligatory number	EJU Vest Photo blue	EJU Vest Medical white
Cadet European Cup	5	5
Junior & Senior European Cups	8	8
European Open	15	8
European Judo Championships Cadets, Juniors, U23	25	10
European Judo Championships Seniors	40	10
European Judo Championships Clubs	30	10
European Judo Championships Veterans	15	10
European Judo Championships Kata	10	0



15.17 Promotional materials

Organizer is obliged to produce printed promotional materials for Senior European Championships in B2 and Billboard format. Promo flyers are also welcome. Recommendation for the LOC is to with promotion not later than one month before the event. All materials before printing should be approved by EJU.

For all other European Championships, European Opens, European Cups recommendation is to produce at least posters in B2 format. All materials should be approved by EJU

15.18 Event promotion - Press conference & PR (before event)

Organizer of the European Championships should organize press conference with local media not later than 14 days before the event. It's advised to LOC to reach out more media attention with paid "Promo articles" in their printed and digital media. If needed EJU will assist with coordinating,

Event advertising platforms:

- Radio advertising
- Billboards in the city
- Local TV announcement
- Local digital/printed newspapers
- Support of the tourist offices
- Social platforms

16. Media

16.1 Press tribune & Media Centre

The press tribune and media centre equipped with provided basic requirements is crucial for every media representative at the European Championships.

Press tribune should be easily accessible with a clear view of all competition areas and is preferably to be located in the centre of the venue in a higher level. Depending on the number of the accredited media it has to provide enough working space. Press tribune should offer sitting positions, power, internet (cable and wifi) with easy access to the media centre.

Media centre/press room is a working room with tables, chairs, wall-sockets, high speed internet connection (cable), lockers for equipment, TV screens with live feed which should be close to the access at FOP and press tribune. LOC should provide at least one press officer with experience which would follow the instructions given by EJU.

Media centre is a service for all media representatives and it should ensure to provide the following:

- Clean environment
- Enough working spaces
- High speed internet
- Fight order
- Live feed on TV Screens
- Printed material (Draw sheets, program, media guide, etc)
- Drinks and Beverages available
- Lockers available for all TV or Photo reporters
- Exclusive paid telephone lines (upon request in advance)
- Bibs (vest) for Photo and HB in neutral color (black or navy blue)

All media representatives are required to register in advance. Accreditations are approved only by EJU. All registered media have to carry clear marked accreditations, distinguishing PHOTOGRAPHER, HOST BROADCASTER, RIGHTS HOLDER, WRITTEN/ONLINE PRESS, RADIO, TV.

16.2 Photographers

If the accreditation is approved through online system, Photographer is required to pick up his accreditation with designated ID or PASSPORT, they shall be provided with a photo bib/vest by LOC on spot.

The field of play (FOP) has to offer enough access to the photographers and they are to be located as close as possible to the mat, on the same side as the EJU technical table in order not to have people waking around in the background of the FOP.

Photographers have designated dress code and no shorts will be allowed. It's obligatory for LOC to inform the photographers about the dress code and their working positions.

Sitting podest (30-40cm height) for photographers is recommended for LOC to provide during the event.

The minimum lighting for the FOP shall be 1500 lux, however 1800 is our recommendation. It is forbidden to use flash as well as tripod next to tatami (only monopod could be used for photographers).

No photo or equipment bags are authorized next to the tatami.

LOC should provide stable WIFI connection for all photographers on the spot, easy access to drinks and working stations.

16.3 Mixed Zone

Designated area where athletes can be interviewed as soon as they leave the field of play (FOP), known as “Mixed Zone”, should be a space big enough to receive accredited media and located on the way of the athletes from the FOP to the dressing room/warm up area.

It has to be on the logical exit way so that no athletes can leave the competition area without passing through mixed zone. Ideally should be place close to the press facilities (press tribune and press room), to allow quick access of the journalist.

Mixed zone requires proper lighting available and security on site to enforce access and that no personal backgrounds are used.

There need to be barriers and sponsor backwall in background of the athletes. The press should not be able to surround the athletes.

16.4 Media services

EJU in collaboration with LOC is responsible for all media services provided on spot. LOC should appoint designated Press Officer who will get in touch with EJU Media Director in a regular basis starting at least six months before European Championships.

It is recommended that the Press Officer has experience in journalism/reporting/etc., and should speak English.

Press Officer should be available on spot to assist with all above mentioned operations and media relations, including accreditation deadlines, media facilities, situation of the local media, press events and other.

All local events (press conference, sponsor contracts, promotional events, etc.) related to the Championships should be also communicated with EJU Media Department and can be published at the EJU website if needed.

16.5 Event promotion - Press conference & PR (before event)

Organizer of the European Championships should organize press conference with local media not later than 14 days before the event. It’s advised to LOC to reach out more media attention with paid “Promo articles” in their printed and digital media. If needed EJU will assist with coordinating,

Event advertising platforms:

- Radio advertising
- Billboards in the city
- Local TV announcement
- Local digital/printed newspapers
- Support of the tourist offices
- Social platforms
-

17. IT Requirements - European Championships

17.1 Introduction

A proper IT set-up is essential for a successful competition. Please read & follow carefully!

- This document needs to be **forwarded** to the responsible persons and companies in charge of fulfilment. The **experts** in each field need to have these requirements as soon as possible.
- Every **detail** is important. If a specification cannot be fulfilled entirely or certain items cannot be delivered as described: please **communicate** this beforehand with the EJU IT department. All changes need approval.
- The installation time and effort are easily underestimated. Finishing the set-up late at night before start of competition is risky. All needs to be properly tested. Set the right **priorities!**
- If there are any questions, please don't hesitate to contact EJU IT department

17.2 Before start...

The positions in the venue may vary for each event.

We will provide an exact seating plan before the start of cabling.

Additionally, we will add stickers on the tables with the position names and start/end points for each cabling: Local network, internet, audio, video etc.

Therefore, please set the priority to have the podiums (including streaming studio) with tables and covers ready first! Then the cabling can start...

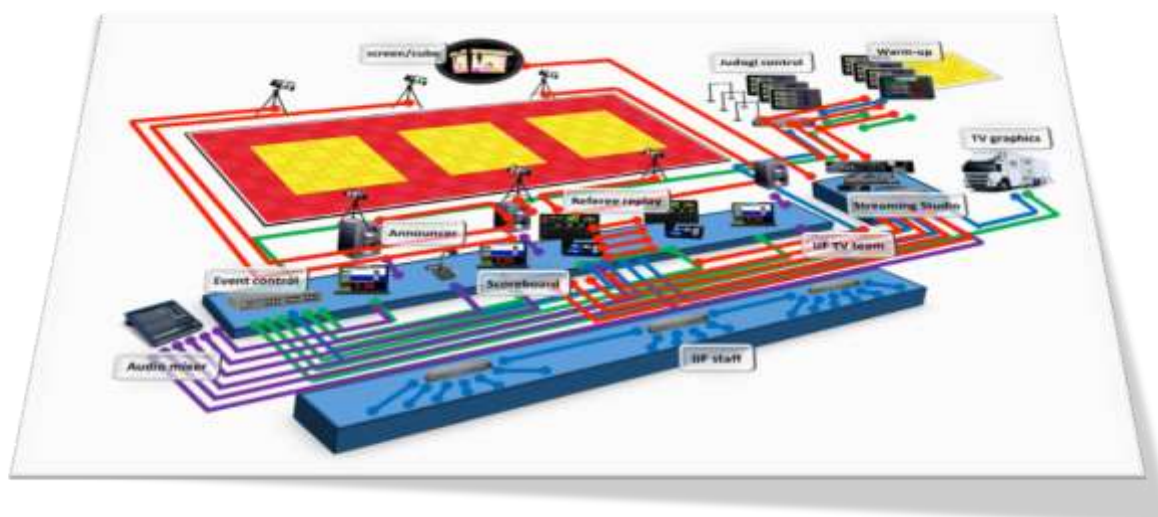

17.3 Equipment + Transport

The EJU IT equipment (video streaming machines, referee replay devices, cameras etc.) will be shipped by a professional logistics company. They will handle all custom procedures.

We need from your federation a contact person. The logistics company will get in touch with you for coordinating the date, time and place for delivery before and the pick-up after the event.

Before and during the event: the cases need to be stored in a safe room in the venue.

17.4 Accreditation cards

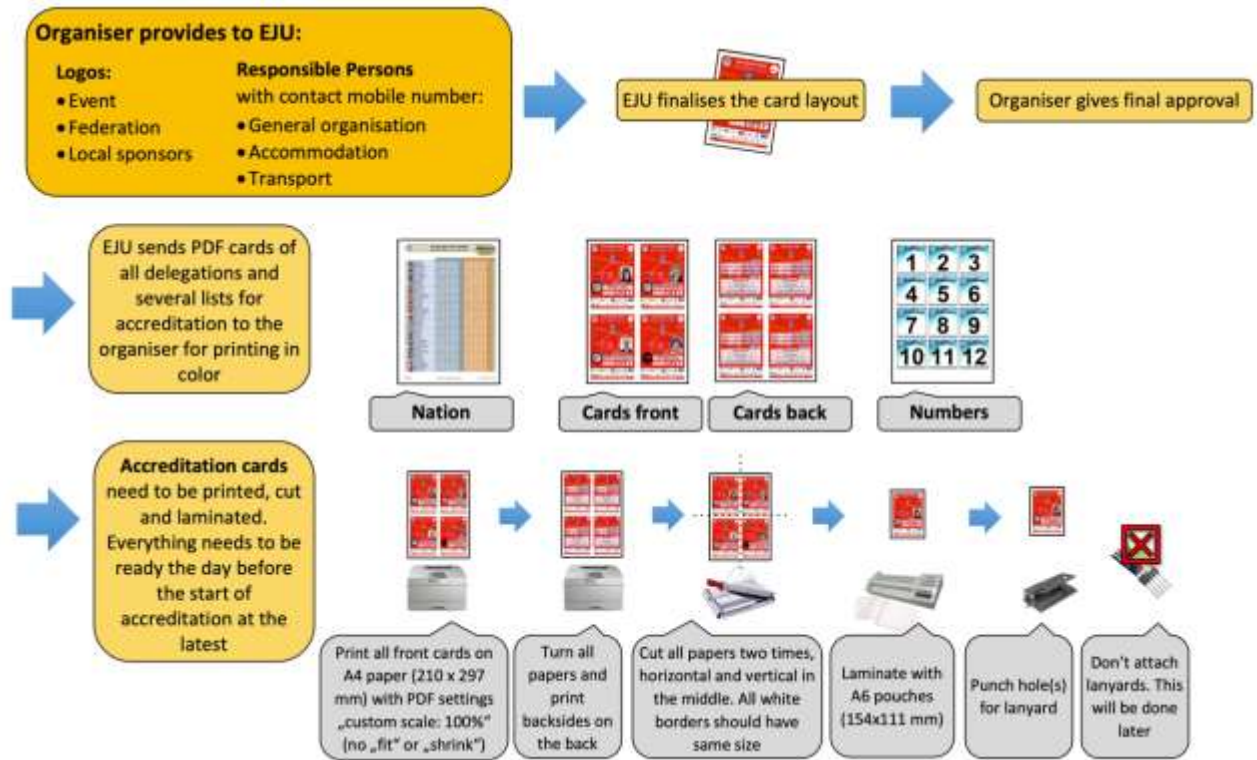

17.5 Accreditation Setup

Checklist		<input checked="" type="checkbox"/>
2	Color laser printer: • 20 ppm or faster • network connection	<input type="checkbox"/>
2	Complete set of toner	<input type="checkbox"/>
1	Copy machine	<input type="checkbox"/>
2	Laminating machines	<input type="checkbox"/>
2	Paper cutter	<input type="checkbox"/>
2	Hole puncher	<input type="checkbox"/>
	Paper A4	<input type="checkbox"/>
	Laminating pouches Exact size: 154x111 mm	<input type="checkbox"/>
	Lanyards	<input type="checkbox"/>
5	Multi-outlet power strips	<input type="checkbox"/>
	Wireless Internet	<input type="checkbox"/>

The room needs to be set-up the evening before the start of accreditation. This includes delivery of all equipment plus the printed and laminated accreditation cards

Network IP addresses from printers need to be set manually to 192.168.2.8 and 192.168.2.9

The same printers (plus toners) need to be taken afterwards to the draw and then to the venue

17.6 Draw



Checklist		<input checked="" type="checkbox"/>
1	Projector (HDMI input, 3000 ANSI Lumen or more)	<input type="checkbox"/>
2	LCD screens* (50", HDMI)	<input type="checkbox"/>
1	HDMI switcher (3x in, 3x out, seamless switching)	<input type="checkbox"/>
1	HDMI splitter (1x in, 3x out)	<input type="checkbox"/>
6	Cabled microphones	<input type="checkbox"/>
2	Wireless microphones	<input type="checkbox"/>
1	Audio mixer (+cables)	<input type="checkbox"/>
	Speakers (+cables)	<input type="checkbox"/>
3	Audio cables	<input type="checkbox"/>
3	Ground loop isolators (for audio signal from laptops)	<input type="checkbox"/>
	HDMI cables	<input type="checkbox"/>
	Internet wireless	<input type="checkbox"/>
	Internet by cable (10 Mbit/s up- and download)	<input type="checkbox"/>
2	Copy machines (50 ppm or faster, with sorting function)	<input type="checkbox"/>

17.7 Power for Referee Replay & Live Streaming

The electricity planning for the whole event must be done by experts using professional power distribution equipment. No line is allowed to come from a simple wall plug!

6x

6x Uninterruptible Power Supplies (UPS):

- Min. power each UPS: 980 Watts / 1440 VA
- Waveform Type: pure Sine wave

Exclusive power lines:

- 2x streaming studio (different phase/circuit than lighting equipment!)
- 1x Event IT
- 1x Referee replay

Multi-outlet power strips:

- With 5 or more plugs each
- No switches

Pure sine wave

Simulated sine

Square

Checklist		<input checked="" type="checkbox"/>
6	UPS as specified	<input type="checkbox"/>
	Multi-outlet power strips	<input type="checkbox"/>
	Power cable extensions	<input type="checkbox"/>

17.8 Electricity points

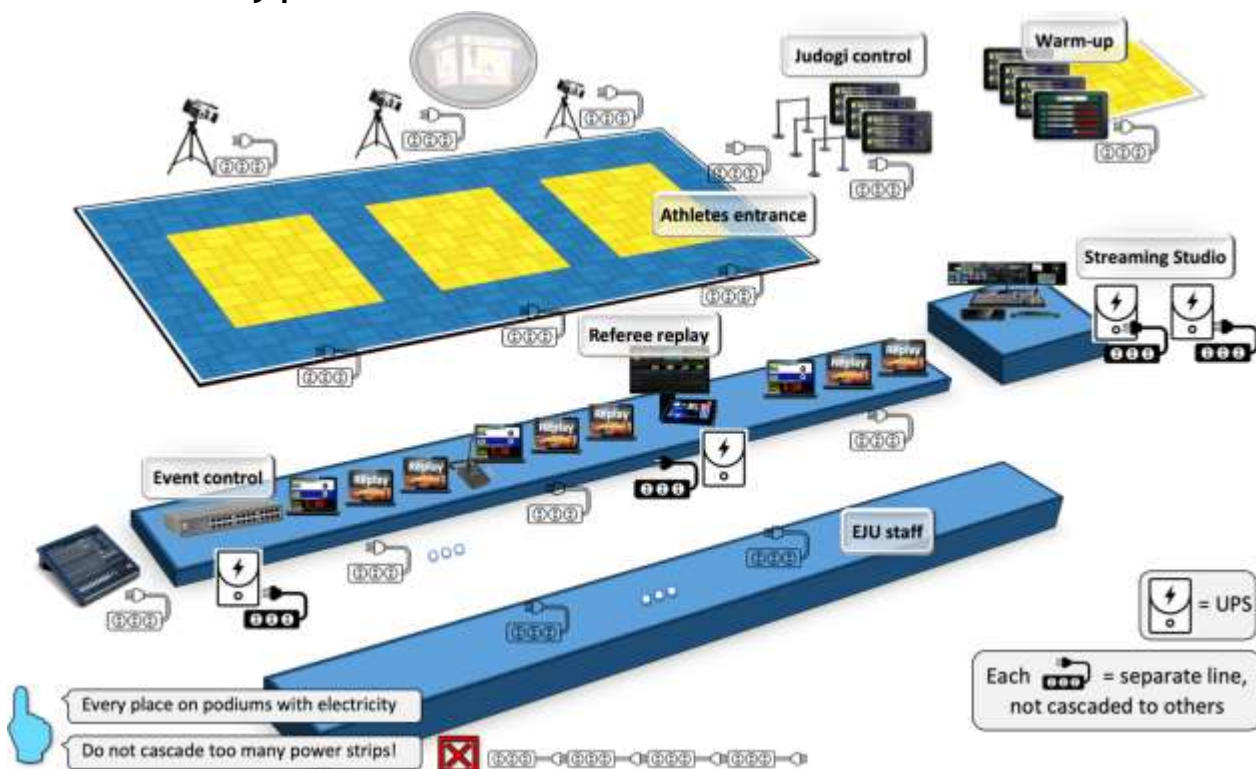

17.9 Laptops

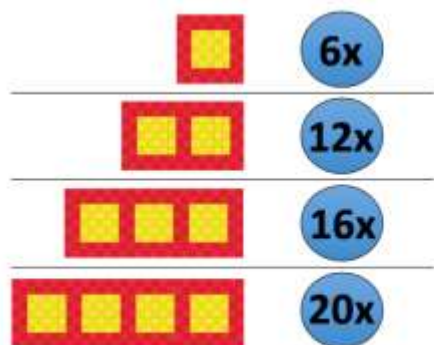

local IP 192.168.2.x	
Location	x
IJF Server	3
Scoreboard	11, 12, 13,...
Judogi control	21, 22, 23,...
Warm-up	31, 32, 33,...
CARE front	41, 42, 43,...
CARE opposite	51, 52, 53,...

Subnet: 255.255.255.0
 Gateway: empty
 DNS: empty

- Hardware Requirements:**
- Up-to-date model
 - For scoreboards:
 - 8 GB RAM
 - Resolution 1920x1080
 - 200 GB disk space free
 - Network input
 - HDMI output
 - Mouse

- Operating System Requirements:**
- MS Windows 10 Professional
 - English language version and keyboard
 - Clean installation
 - No login password
 - Windows firewall; file and printer sharing exception enabled
 - No security suite/Antivirus software/3rd party firewall installed
 - Screensaver/power saver disabled
 - Reduced screen brightness on battery

17.10 Monitors



11x

10x HDMI input 

1x DVI input 

Addition to monitors:

- 1 HDMI Splitter;
- 1IN – 4OUT

All TFT monitors:

- Size: 23"-26"
- Resolution: 1920x1080 Full HD
- Format 16:9
- Input: 10x HDMI, 1x DVI

Checklist		<input checked="" type="checkbox"/>
10	Full-HD TFT monitors with HDMI input	<input type="checkbox"/>
1	Full-HD TFT monitors with DVI input	<input type="checkbox"/>
1	HDMI Splitter 1IN, 4OUT	<input type="checkbox"/>

Additional to Referee Commission monitors - +5m HDMI Cables should be provided for Referee Commission as well as

17.11 Local Network

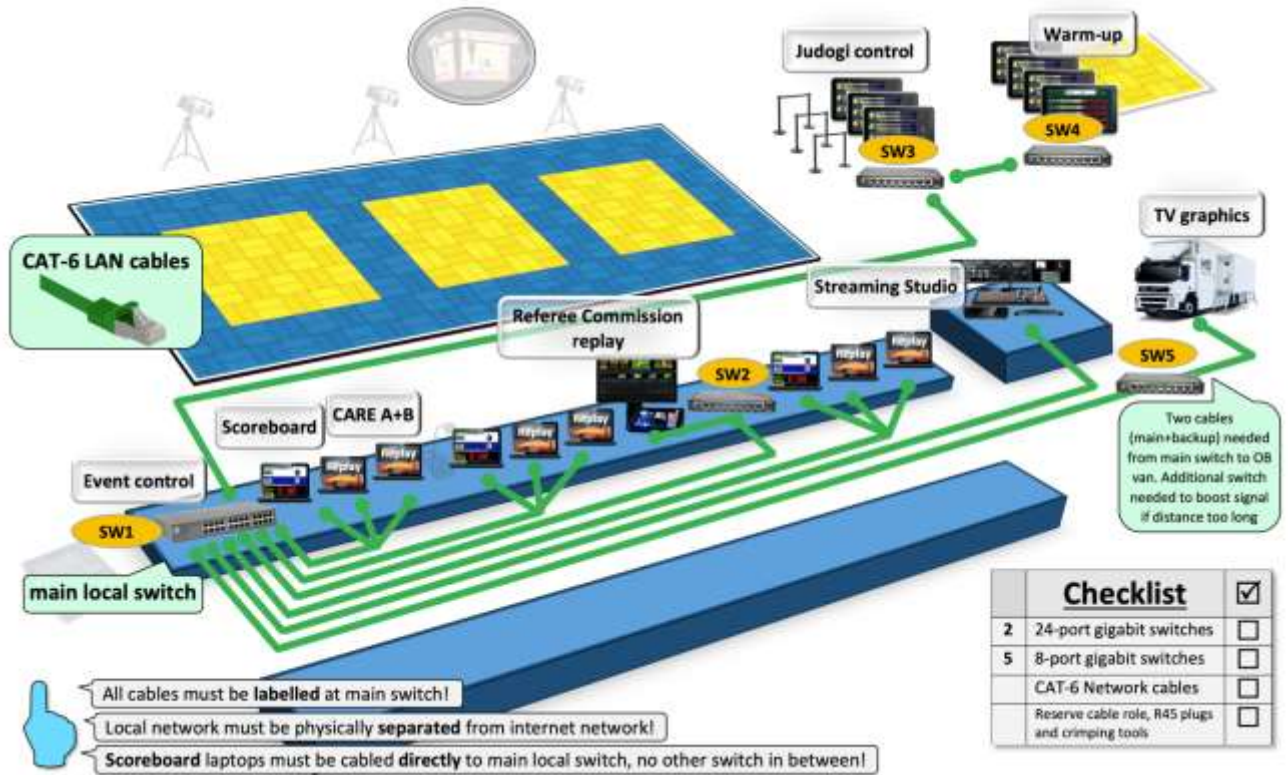

Network switches		
SW1	Main local switch (24 port)	<input checked="" type="checkbox"/>
SW2	Middle-mat local switch (8 port)	<input type="checkbox"/>
SW3	Judogi-control local switch (8 port)	<input type="checkbox"/>
SW4	Warm-up area local switch (8 port)	<input type="checkbox"/>
SW5	Optional: TV-graphics local switch (4 port)	<input type="checkbox"/>

Order of cabling		
1	Cable from main local switch to EJU streaming studio place	<input type="checkbox"/>
2	Cables from main local switch to scoreboard laptops mat 1, 2, 3, ...	<input type="checkbox"/>
3	Cables from main local switch to CARE laptops mat 1, 2, 3, ...	<input type="checkbox"/>
4	Cable from main local switch to judogi-control local switch	<input type="checkbox"/>
5	Cables from judogi-control switch to judogi-control laptops	<input type="checkbox"/>
6	Cable from judogi-control switch to warm-up area local switch	<input type="checkbox"/>
7	Cables from warm-up area switch to warm-up area laptops	<input type="checkbox"/>
8	Cable from main local switch to middle-mat local switch	<input type="checkbox"/>
9	Cables from middle-mat-switch to EJU replay machine	<input type="checkbox"/>
10	Cable and back-up cable from main local switch to TV-graphics place (using additional switch if distance too long)	<input type="checkbox"/>



Key points:

- Whenever a cable is ready:
 - Label with target location
 - Ping test
- No broken latches!



17.12 Internet Network

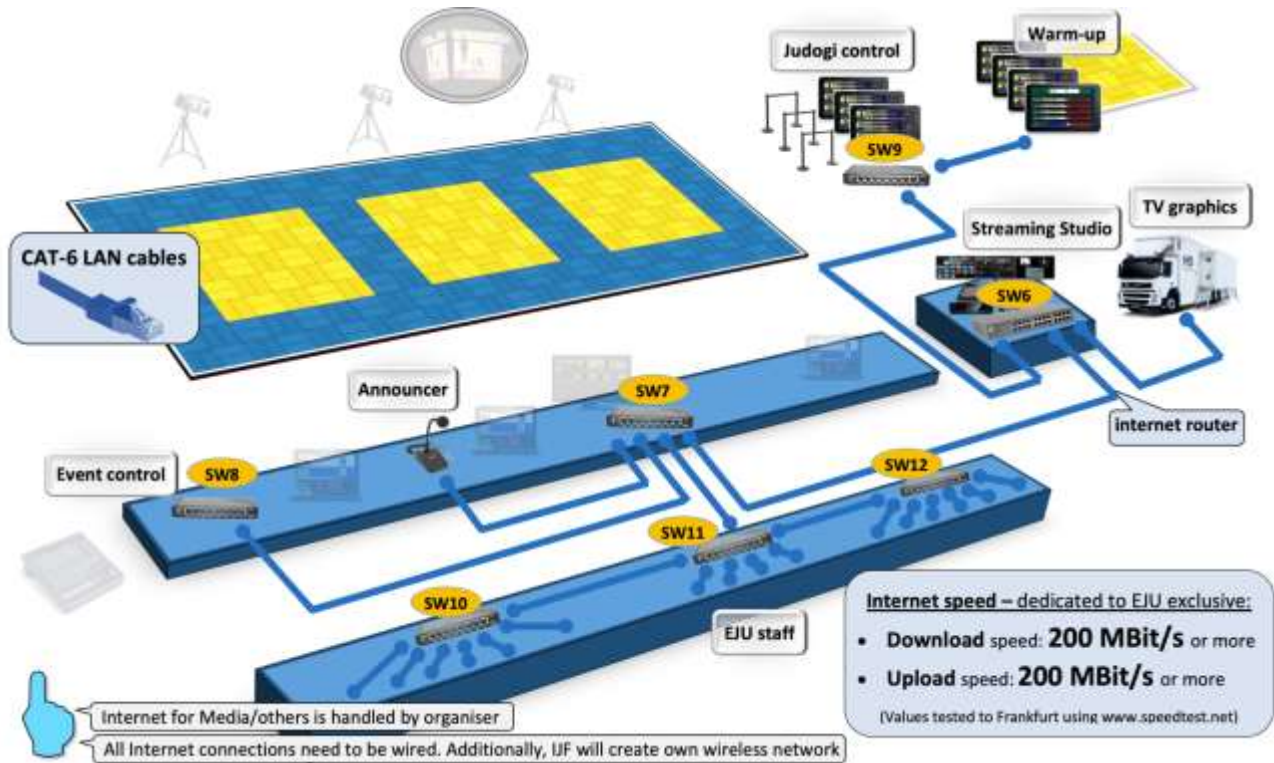

Network switches		<input type="checkbox"/>
SW6	EJU main internet switch located at EJU streaming studio	<input checked="" type="checkbox"/>
SW7	Middle-mat internet switch (8 port)	<input type="checkbox"/>
SW8	Event control internet switch (8 port)	<input type="checkbox"/>
SW9	Judogi-control internet switch (8-port)	<input type="checkbox"/>
SW10-12	Staff internet switches (8 port)	<input type="checkbox"/>



Order of cabling		<input type="checkbox"/>
11	Cable from main internet switch to middle-mat internet switch	<input type="checkbox"/>
12	Cables from middle-mat internet switch to speakers place	<input type="checkbox"/>
13	Cable from middle-mat switch to event control place	<input type="checkbox"/>
14	Cable from middle-mat internet switch to staff internet switches	<input type="checkbox"/>
15	Six cables from each staff internet switches to nearby EJU staff places	<input type="checkbox"/>
16	Cable from main internet switch to TV graphics in OB van	<input type="checkbox"/>
17	Cable from main internet switch to judogi-control area	<input type="checkbox"/>
18	Cables from judogi control internet switch to warm-up place (TBC)	<input type="checkbox"/>

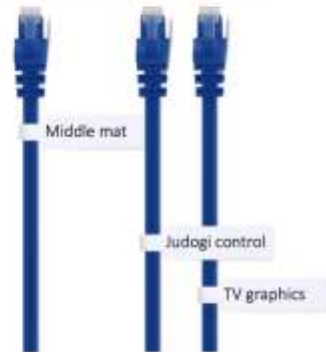

Key points:

- Whenever a cable is ready:
 - Label with target location
 - Ping test
- No broken clips



For main internet line do not use IP 192.168.2.x as it is reserved for the local network!

17.13 Local Network 10Gbit



IT Requirements

Local Network 10 GBit



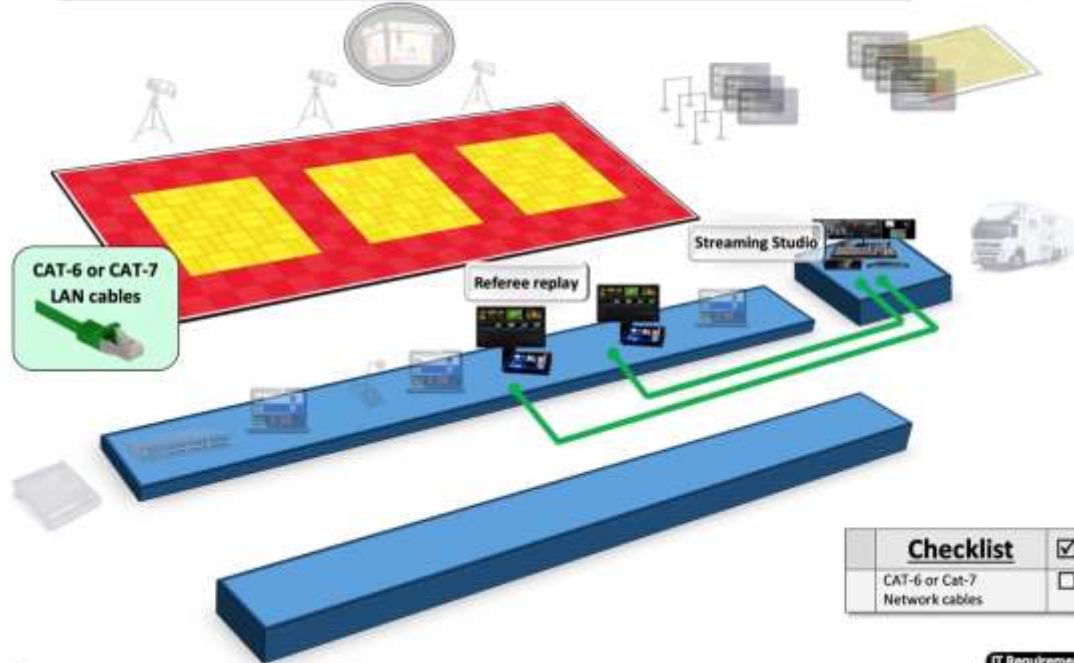

Checklist	
CAT-6 or Cat-7 Network cables	<input checked="" type="checkbox"/>

IT Requirements

17.14 Scoreboards

LED board controller

MS Windows 10 required!



USB DI box

Connection from laptop via HDMI out

LED pannels scoreboard: >200 vertical pixel per meter recommended (min. 96 pixel/meter)

Checklist

- 1 LED screen 55" or bigger 16:9, HDMI input
- 1 LED board controller
- 1 converter HDMI to LED board input (if needed)
- 1 HDMI Splitter (1x in, 2x out)
- 1 Laptop
- 1 USB DI box
- 1 Scoreboard keyboard
- HDMI cables
- 1 Big active speaker
- XLR audio cables (from laptop to backup speaker and venue mixer)

17.15 Scoreboard Operators

2x

4x

6x

8x

Scoreboard operators from local organiser:

- >=18 years old
- English speaking
- Judo referee license

Introduction and briefing:

New users: Day before start of competition at 19:00 in the venue

Experienced: First day of competition, one hour before start in venue

Checklist



List of names of all scoreboard operators



17.16 Gong & Audio Set-up

XLR audio cables



big active speakers with amplifier at each mat, independent from mixer

Jack connector (¼ inch). All other connections by XLR



USB DI box, like Peavey USB-P

Checklist



Venue speaker system



Professional audio mixer, connected to venue speaker system



Active speakers with amplifier each tatami



XLR cables



1 Jack connector (¼ Inch)



Check carefully for ground loop hum and buzzing noises!

At each mat: Additional big **active speakers**
with **amplifier** and **XLR input**

- Used solely for gong signals from each mat as backup
- Directly connected to DI boxes from scoreboard laptops
- Gong signal must be heard in venue with noisy crowd

17.17 Video Cabling

17.17.1 Option when TV providing front camera signals from all mats on all days

HD-SDI cables BNC

Use high quality HD-SDI cables (RG59, 75 ohm)

Use HD-SDI repeater or BNC <-> optical fibre for long distances!

Checklist

- HD-SDI video cables (RG59, 75 ohm) with BNC connectors
- 2x HD-SDI distributors per mat or matrix
- HD-SDI repeater / optical fibre converters
- HD-SDI test monitor
- Reserve: HD-SDI BNC cable role 100-200 m, BNC connectors & crimping tools

HD-SDI cables BNC



All signals as HD-SDI with audio embedded!

17.17.2 Option when front camera signals are NOT provided by TV for entire event



HD-SDI cables BNC

HD-SDI video cameras with tripods needed for each mat

Use high quality HD-SDI cables (RG59, 75 ohm)
Use HD-SDI repeater or BNC <-> optical fibre for long distances!

Checklist

- HD-SDI video cameras with tripods for each mat
- HD-SDI video cables BNC
- 2x HD-SDI distributors per mat or matrix
- HD-SDI repeater/converter
- HD-SDI test monitor
- Reserve: HD-SDI cable role 100-200 m, BNC connectors & crimping tools

17.18 Video Camera operators

With TV covering front mats

Without TV covering front mats

- | | |
|-----------|------------|
| 6x | 8x |
| 8x | 12x |
| 6x | 12x |
| 8x | 16x |

Camera operators from local organiser:

- >=18 years old
- English speaking
- Judo background

Introduction and briefing:

First day of competition, one hour before start in venue

Checklist

-
- Name and contact details of responsible person for operators
- List of names of all camera operators

17.19 Streaming Studio

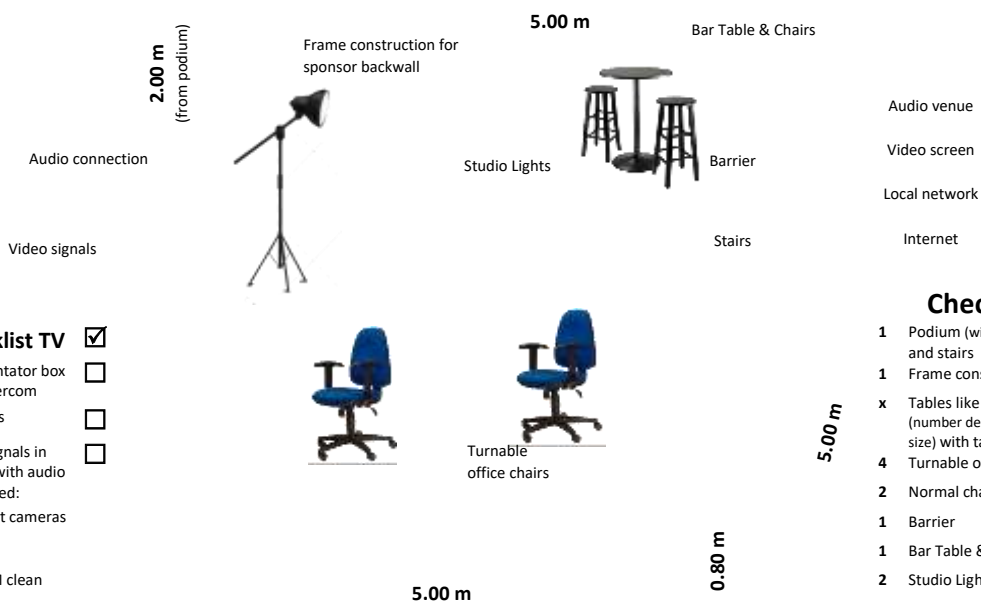

Checklist TV

-
- 1 Commentator box with intercom
- 2 Headsets
- Video signals in HD-SDI with audio embedded:
- Front cameras
-
- PGM clean

Checklist

-
- 1 Podium (with carpet) and stairs
- 1 Frame construction
- x Tables like in plan (number depends on size) with table cloths
- 4 Turnable office chairs
- 2 Normal chairs
- 1 Barrier
- 1 Bar Table & Chairs
- 2 Studio Lights

17.20 Information system

Referee Draw

Contest order

Coach Assistant

Live TV from each mat

2x

2x per mat

Number of screens can be reduced by showing more than one mat on each screen.
Number of laptops can be reduced by using HDMI splitters and long HDMI cables cloning the signals

1-2x

Touchscreens recommended

1 per mat

Signals and cabling done by organiser. IJF can provide HD-SDI signals from IJF Streaming Studio. HD-SDI to HDMI or analogue converters and cables needed.

Checklist

-
- LCD screens size 50" or more
- Touchscreens for coach assistant
- Laptops connected to local network
- HDMI cables
- Video cables

17.21 Referee Radios

8x

16x

24x

32x

+

+

Checklist

-
- Radios
- Security headset
- Charger
- Responsible person*

Each tatami needs it's own frequency!

Responsible person should bring, charge every night and help referees with radio

17.22 After Competition

...keep running:

Electricity**Internet****Lights**

After the competition is finished our teams still need time to finalise the work
(interviews, video highlight editing, news uploading etc.)

Therefore, it is essential that **electricity**, **internet** and **lights** are kept on and intact until the last working person from EJU gives green light that it is no longer needed.

Important: Please inform **all** persons and companies involved in the dismantling on the **last day!**

18. TV Requirements

18.1 Production Philosophy of the International Feed

The Organizer shall have produced an International Feed by a local TV station or production company, hereafter the Host Broadcaster.

The International Feed should be a continuous broadcast high quality signal in High Definition 16:9 with action and graphics safe 4:3, with full international sound and effects of all fights of the Final Block. The Final Block is defined as the block comprising all the repechage finals, semi-finals, bronze medal contests and finals of all weight category of each day of the individual event and of all medal contests of the team event.

The International Feed shall include:

- Complete fight action
- Opening sequence and logo and may include establishment shots of the host city and venue
- Fighters announcements and entry on the mat/tatami
- Replays from the previous fight during pauses between fights

The international signal running order will be sent to the Host Broadcaster by the EJU prior to the event.

The international audio feed shall be full international sound with arena side effects. Careful planning must be made to have microphones near the mats/tatami to capture the best quality fight audio and crowd atmosphere effects.

The International Feed shall be integrated with high resolution graphics in the English language, such graphics shall be provided to the Host Broadcaster by EJU. The graphics shall be used in the International Feed in compliance with the instructions given by EJU (Graphics guidelines).

18.2 Delivery of the International Feed

The European Judo Championships will be distributed in High Definition. The Organizer shall deliver to the EJU the International Feed signal free of charge live on the W2A or W3 satellite. The technical parameters used and band width booked shall be in compliance with the best international standards with ideally 18Mhz (and not less than 12Mhz) in DVBS2 for standard High Definition production.

Feed shall be made available on satellite free of charge with the conditions described here-above.

HD feed will have the following audio configuration:

Audio 1 - International sound stereo L

Audio 2 - International sound stereo R

Audio 3 - EJU English commentary

Audio 4 - available for broadcasters

The transmission timings of the international feed will be decided with the EJU when the final block planning is established.

The Organizer shall also deliver to the EJU the live signal of the International Feed free of charge on site.

18.3 Programmes

The Host Broadcaster shall produce a fifteen (15) minutes highlight program of each day of competition of the Event, including graphics and international sound which will be available on the same satellite as the one used for the International Feed, and to be placed on the satellite maximum one (1) hour after the end of the last medal ceremony of the relevant day.

At the end of the Event the Host Broadcaster shall produce a twenty six (26) minutes highlight of the whole Event (all days) including graphics and international sound. The highlight program will be available on the same satellite as the one used for the International Feed, and to be placed on the satellite maximum one (1) hour after the end of the Event.

The transmission timing of the daily Highlight program and the 26 minutes highlight program will be discussed with the Host Broadcaster before the event.

18.4 Production Plan for the Production of the International Feed

The guiding principle for all coverage of the European Judo Championships is to make it as consistent as possible from Host Broadcasters to Host Broadcasters and from country to country. Therefore, Host Broadcasters must follow the following minimum camera positions plan and fulfil their obligations.

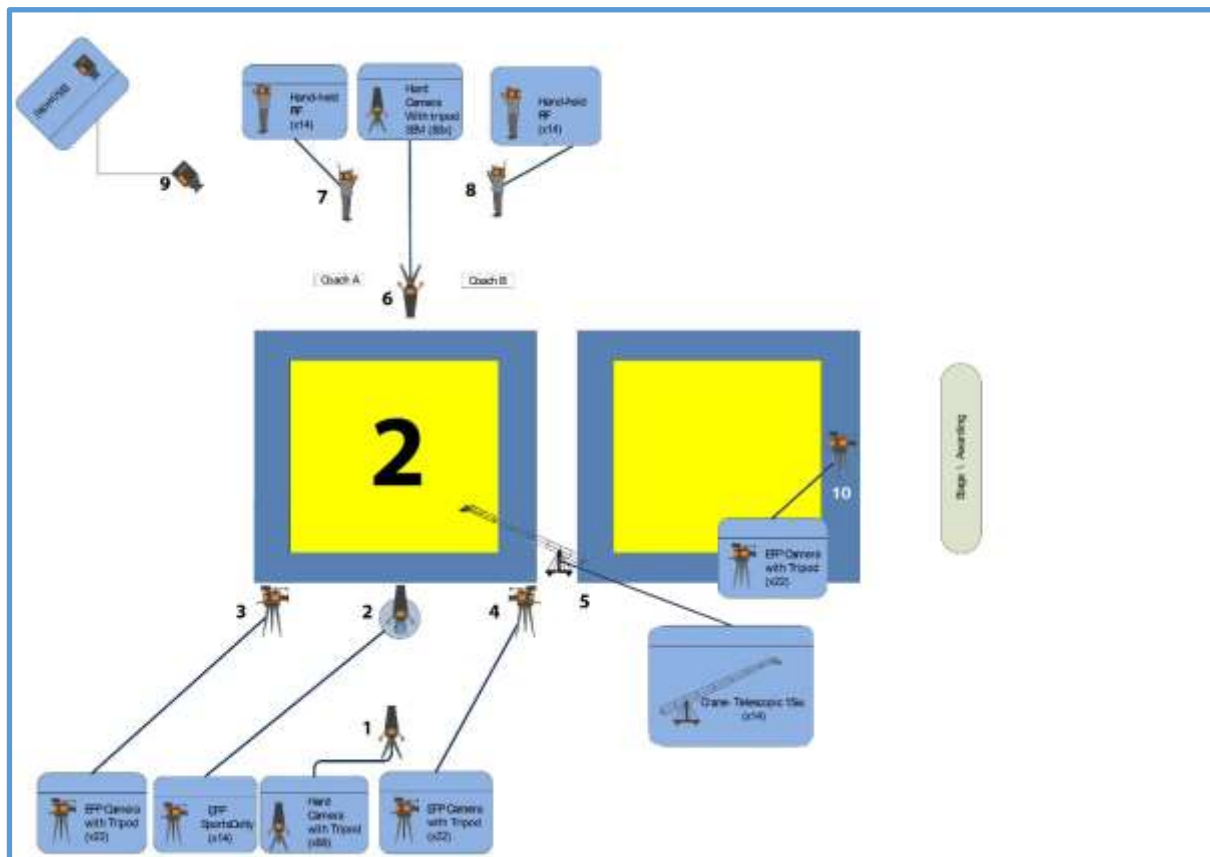

During the preliminaries all four mats must be covered by at least one camera and the signal must be provided to EJU live streaming studio and to the EJU Refereeing commission (HD SDI EMBEDDED AUDIO CLEAN PGM with audio embedded)

The Host Broadcaster cameras must be set up as to show the advertising boards and the largest public possible.

Camera platforms shall have to be provided for at least the minimum number of cameras. Those platforms must be dissociated from public stands, must be fully secured and their access must be limited and under control.

In addition to the Host Broadcaster cameras, EJU may also request unilateral camera positions for its media rights holders.

ALL OPERATORS need to be available on the day before the event for briefing on their respective roles and jobs. There will be a rehearsal of the walk on and awarding ceremonies at five o'clock.

The team should be contracted to work all day on each day of judo to ensure adequate practice time. They will also be needed for the EJU internet streaming.

CAMERAS

10 HD cameras including:

1 crane (9-15 metres length)

1 super slow motion camera (75 fps)

2 long lenses (eg 75x)

1 low tripod for the central camera.

2 RF camera

REPLAY SYSTEMS

A minimum of 3 EVS XT2 systems (or 2 XT3) (networked) with operators need to be provided.

Only EVS brand is acceptable, no other type of system such as ORAD, 3play etc.

K2 dyno is also ok.

FLOOR MANAGER

EJU floor manager needs monitor and Dirty PGM signal (Format is not important)

INTERVIEWS

Camera and tripod with MIC and lighting need to be made available for interviews after the last awarding ceremony.

DRESS CODE

All operators in black with NO shorts allowed.

GRAPHICS

We have our own in house graphics team who will work inside the OB van.

They will require the following:

- A space next to me inside the OB van from which they can see the PGM.
- A monitor for their own output
- A network cable from the EJU IT team to their position (you can liaise with the organiser about providing this)
- HD SDI graphics video input (This is a DVE created from the mixer with the two shoulder cameras).
- Genlock (blackburst) and power.

18.5 Recordings

The Host Broadcaster shall deliver to EJU at the end of the Event:

- Records of the International Feed of each Final Block of the Event with
 - Audio 1: International Sound Left
 - Audio 2: International Sound Right
 - Audio 3 and 4: English commentary;
- Records of the International Feed of Elimination all mats, each contest as separate file with:
 - Audio 1: International Sound Left
 - Audio 2: International Sound Right

the records format will be discussed prior to the event with the Host Broadcaster.
- Two (2) Hard Discs recordings of the International Feed with International sound of each Final Block of the Event.
- Hard Discs should be provided by HB.

18.6 Coordination of International Rights Holders Requirements

18.6.1 Commentary Positions

The Organizer shall provide to EJU as many commentary positions as required by the EJU, free of charge. Commentary position could be fully equipped or partially equipped.

The commentary positions shall have an uninterrupted view of the entire arena and as close as possible to the centre of the arena in order to have a view on all and each mat/tatami. There should be enough space behind the seats to allow other commentators to reach their position and technical crew to go back and forth for any reason without disturbing anyone else. There should be enough space between each commentary position in order for the different commentators to not disturb each other. The access to commentary positions must be separated from the general public and these positions must be fully secured.

Each fully equipped commentary position shall include:

- As many monitor as there are feeds produced in the International Feed, or one monitor with two (2) channels.
- 1 monitor for statistics (Commentary information system), such statistics will be provided by the EJU
- The monitors shall be colour television monitors of a minimum of 14 inches diagonal;
- Commentator unit/production mixer with 2 or 3 headsets with incorporated microphones;
- at least four (4) electrical plugs (16A/position, redundant and on the same phase as the technical facilities); and at least the capacity for coordination and programme feedback
- The commentary could be made available on satellite if requested
- Technical assistance

Each partially equipped commentary position shall include:

- As many monitor as there are feeds produced in the International Feed, or one monitor with two (2) channels.
- 1 monitor for statistics (Commentary information system), such statistics will be provided by the EJU
- The monitors shall be colour television monitors of a minimum of 14 inches diagonal;

All commentary positions shall be set up the day before the start of the event and available at least three (3) hours before the Final Block for commentators' orientation and system testing.

The number of Commentary Positions required shall be confirmed by the EJU to the Organizer not later than three (3) days before the start of the Event.

18.6.2 Pre and Post Fight Unilaterals

The EJU may request pre and/or post Final Block unilaterals for its Media Rights Holders coming on site (use of one live camera and/or OB play out facility). This service will be planned together with the Host Broadcaster.

For pre event stand-up and post event interviews, one hand held camera from the Host Broadcaster shall be used, free of charge and according to EJU's instructions. The Host Broadcaster shall provide an IFB and two (2) hand held microphones at the interview position.

Such pre and post unilaterals will be sent live by satellite prior and after the international feed.

Pre and post event unilateral may be conducted in front of the TV backdrop provided by the EJU.

18.6.3 Telecom installations

The Organizer shall make sure that the National Telecom will be able to provide all the installations for all the Medias coming on site and particularly the provision of ISDN line for on-site commentary.

Broadcasters coming on site must book commentary circuits and line (ISDN Line and analogue line) via their own National Telecom Company, with a copy to the Host Broadcaster.

The Host Broadcaster should be responsible for Telecom communication and coordination prior to the event and during the event.

18.6.4 Other Services

Some international broadcasters may wish to personalise the International Feed and to come on site with additional unilateral production facilities.

Specific care shall be taken in the planning to welcome such additional facilities (available space in the compound, in-arena space for unilateral TV studio, live cameras positions for filming part of the fights or live interviews).

All final details regarding commentary positions, mixed zones, studio space, technical parking, lighting and power, offices, security, accreditations, etc. shall be discussed between EJU and the Host Broadcaster.

The EJU will also make sure the Host Broadcaster fulfil the minimum Host broadcast production requirements in order to ensure a standardized high quality production and consistency.

The EJU will stay the main contact for its Media Rights holders and will take care of their entire on site requirements. The Host broadcaster must then supply to EJU all the necessary information for services and facilities made available on site at least one (1) month prior to the event.

19. IT Requirements - European Open

19.1 Introduction

A proper IT set-up is essential for a successful competition. Please read & follow carefully!

- This document needs to be **forwarded** to the responsible persons and companies in charge of fulfilment. The **experts** in each field need to have these requirements as soon as possible.

- Every **detail** is important. If a specification cannot be fulfilled entirely or certain items cannot be delivered as described: please **communicate** this beforehand with the EJU IT department. All changes need approval.

- The installation time and effort are easily underestimated. Finishing the set-up late in the night before start of competition is risky. All needs to be properly tested. Set the right **priorities!**

- If there are any questions, please don't hesitate to contact EJU IT department

19.2 Before start...

The positions in the venue may vary for each event.

We will provide an exact seating plan before the start of cabling.

Additionally, we will add stickers on the tables with the position names and start/end points for each cabling: Local network, internet, audio, video etc.

Therefore, please set the priority to have the podiums (including streaming studio) with tables and covers ready first! Then the cabling can start...

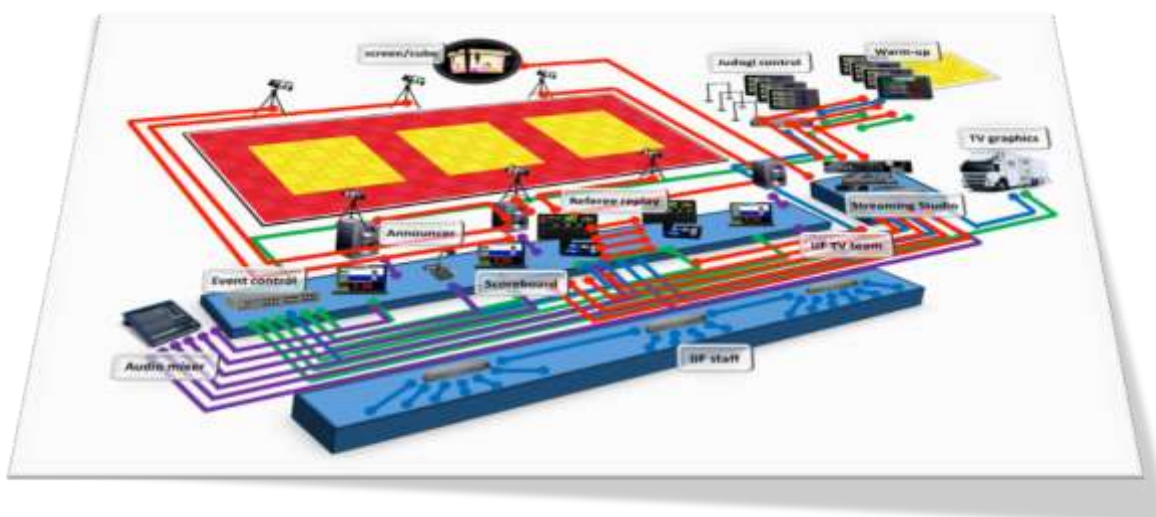

19.3 Equipment + Transport

The EJU IT equipment (video streaming machines, referee replay devices, cameras etc.) will be shipped by a professional logistics company. They will handle all custom procedures.

We need from your federation a contact person. The logistics company will get in touch with you for coordinating the date, time and place for delivery before and the pick-up after the event.

Before and during the event: the cases need to be stored in a safe room in the venue.

19.4 Accreditation cards

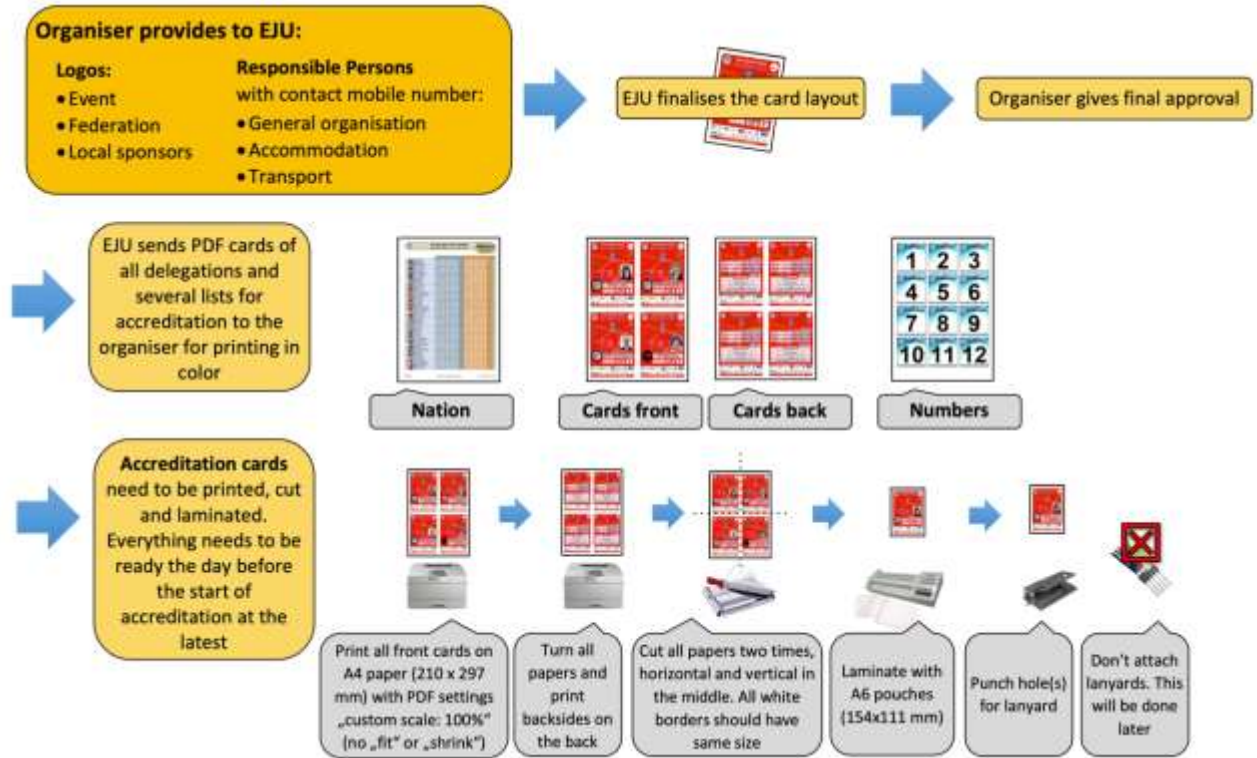

19.5 Accreditation Setup

Checklist		<input checked="" type="checkbox"/>
2	Color laser printer: • 20 ppm or faster • network connection	<input type="checkbox"/>
2	Complete set of toner	<input type="checkbox"/>
1	Copy machine	<input type="checkbox"/>
2	Laminating machines	<input type="checkbox"/>
2	Paper cutter	<input type="checkbox"/>
2	Hole puncher	<input type="checkbox"/>
	Paper A4	<input type="checkbox"/>
	Laminating pouches Exact size: 154x111 mm	<input type="checkbox"/>
	Lanyards	<input type="checkbox"/>
5	Multi-outlet power strips	<input type="checkbox"/>
	Wireless Internet	<input type="checkbox"/>

The room needs to be set-up the evening before the start of accreditation. This includes delivery of all equipment plus the printed and laminated accreditation cards

Network IP addresses from printers need to be set manually to 192.168.2.8 and 192.168.2.9

The same printers (plus toners) need to be taken afterwards to the draw and then to the venue

19.6 Draw

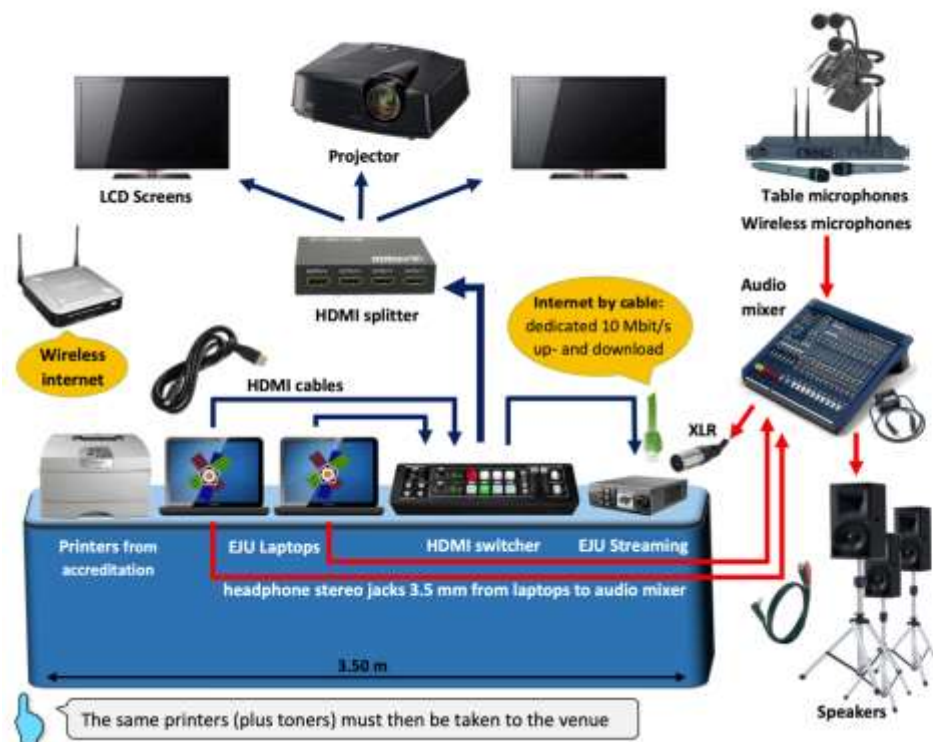

Checklist		<input checked="" type="checkbox"/>
1	Projector (HDMI input, 3000 ANSI Lumen or more)	<input type="checkbox"/>
2	LCD screens* (50", HDMI)	<input type="checkbox"/>
1	HDMI switcher (3x in, 3x out, seamless switching)	<input type="checkbox"/>
1	HDMI splitter (1x in, 3x out)	<input type="checkbox"/>
6	Cabled microphones	<input type="checkbox"/>
2	Wireless microphones	<input type="checkbox"/>
1	Audio mixer (+cables)	<input type="checkbox"/>
	Speakers (+cables)	<input type="checkbox"/>
3	Audio cables	<input type="checkbox"/>
3	Ground loop isolators (for audio signal from laptops)	<input type="checkbox"/>
	HDMI cables	<input type="checkbox"/>
	Internet wireless	<input type="checkbox"/>
	Internet by cable (10 Mbit/s up- and download)	<input type="checkbox"/>
2	Copy machines (50 ppm or faster, with sorting function)	<input type="checkbox"/>

19.7 Power for Referee Replay & Live Streaming

3x

3x Uninterruptible Power Supplies (UPS):

- Min. power each UPS: 980 Watts / 1440 VA
- Waveform Type: pure Sine wave

Pure sine wave

Simulated sine

Square

Exclusive power lines:

- 2x streaming studio (different phase/circuit than lighting equipment!)
- 1x Event IT

Multi-outlet power strips:

- With 5 or more plugs each
- No switches

Checklist

3	UPS as specified	<input checked="" type="checkbox"/>
	Multi-outlet power strips	<input type="checkbox"/>
	Power cable extensions	<input type="checkbox"/>

19.8 Electricity points

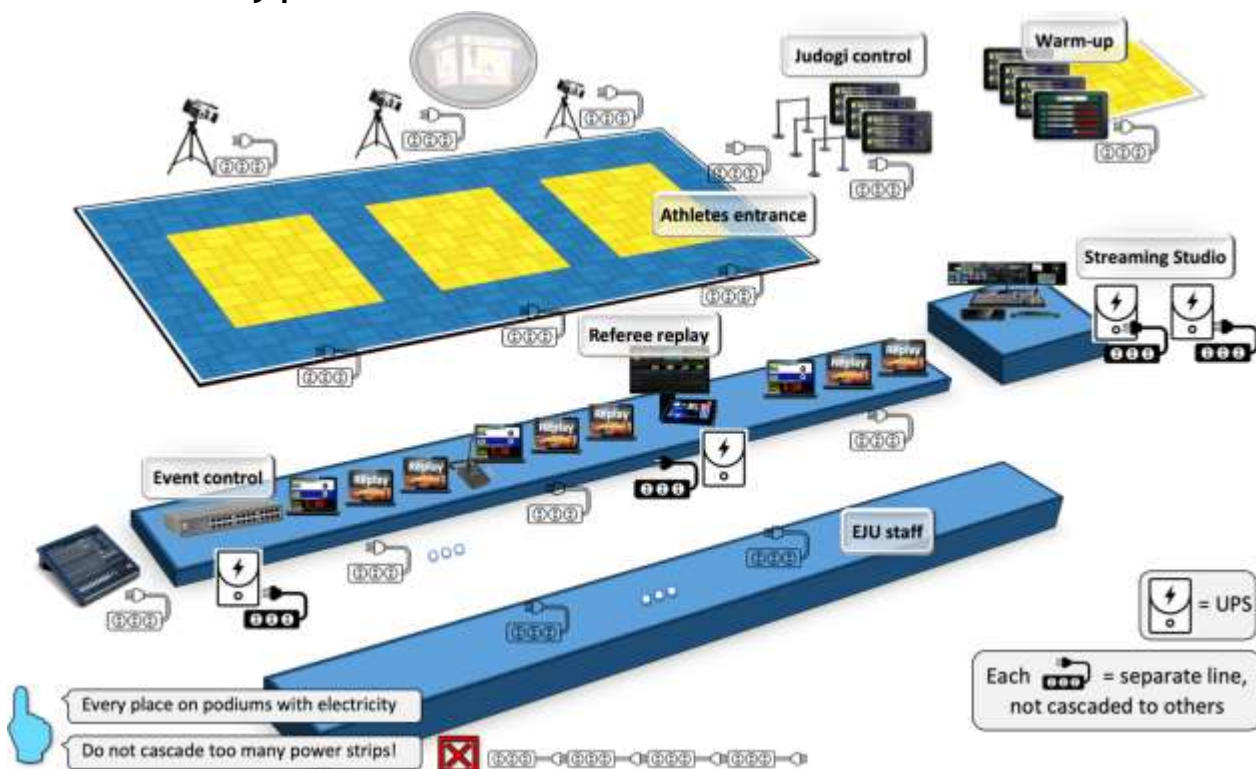

19.9 Laptops

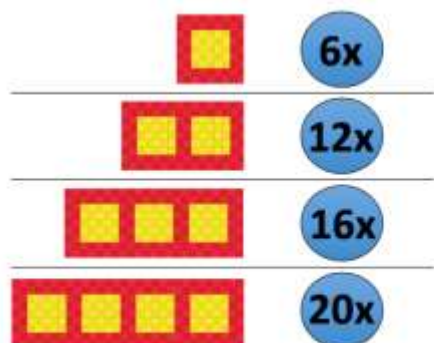

local IP 192.168.2.x	
Location	x
IJF Server	3
Scoreboard	11, 12, 13,...
Judogi control	21, 22, 23,...
Warm-up	31, 32, 33,...
CARE front	41, 42, 43,...
CARE opposite	51, 52, 53,...

Subnet: 255.255.255.0
 Gateway: empty
 DNS: empty

- Hardware Requirements:**
- Up-to-date model
 - For scoreboards:
 - 8 GB RAM
 - Resolution 1920x1080
 - 200 GB disk space free
 - Network input
 - HDMI output
 - Mouse

- Operating System Requirements:**
- MS Windows 10 Professional
 - English language version and keyboard
 - Clean installation
 - No login password
 - Windows firewall; file and printer sharing exception enabled
 - No security suite/Antivirus software/3rd party firewall installed
 - Screensaver/power saver disabled
 - Reduced screen brightness on battery

19.10 Monitors

6x

HDMI input

All TFT monitors:

- Size:** 23"-26"
- Resolution:** 1920x1080 Full HD
- Format** 16:9
- Input:** HDMI

Checklist

-
- 6 Full-HD TFT monitors with HDMI input

19.11 Local Network

CAT-6 LAN cables



SW1



main local switch

All cables must be **labelled** at main switch!

Local network must be physically **separated** from internet network!

Scoreboard laptops must be cabled **directly** to main local switch, no other switch in between!

SW2

SW3

Replay

Replay

Replay



Checklist

-
- 2 24-port gigabit switches
- 3 8-port gigabit switches
- CAT-6 Network cables
- Reserve cable role, R45 plugs and crimping tools

Network switches		<input type="checkbox"/>
SW1	Main local switch (24 port)	<input checked="" type="checkbox"/>
SW2	Middle-mat local switch (8 port)	<input type="checkbox"/>
SW3	Judogi-control local switch (8 port)	<input type="checkbox"/>
SW4	Warm-up area local switch (8 port)	<input type="checkbox"/>
SW5	Optional: TV-graphics local switch (4 port)	<input type="checkbox"/>

Order of cabling		<input type="checkbox"/>
1	Cable from main local switch to EJU streaming studio place	<input type="checkbox"/>
2	Cables from main local switch to scoreboard laptops mat 1, 2, 3, ...	<input type="checkbox"/>
3	Cables from main local switch to CARE laptops mat 1, 2, 3, ...	<input type="checkbox"/>
4	Cable from main local switch to judogi-control local switch	<input type="checkbox"/>
5	Cables from judogi-control switch to judogi-control laptops	<input type="checkbox"/>
6	Cable from judogi-control switch to warm-up area local switch	<input type="checkbox"/>
7	Cables from warm-up area switch to warm-up area laptops	<input type="checkbox"/>
8	Cable from main local switch to middle-mat local switch	<input type="checkbox"/>
9	Cables from middle-mat-switch to EJU replay machine	<input type="checkbox"/>
10	Cable and back-up cable from main local switch to TV-graphics place (using additional switch if distance too long)	<input type="checkbox"/>

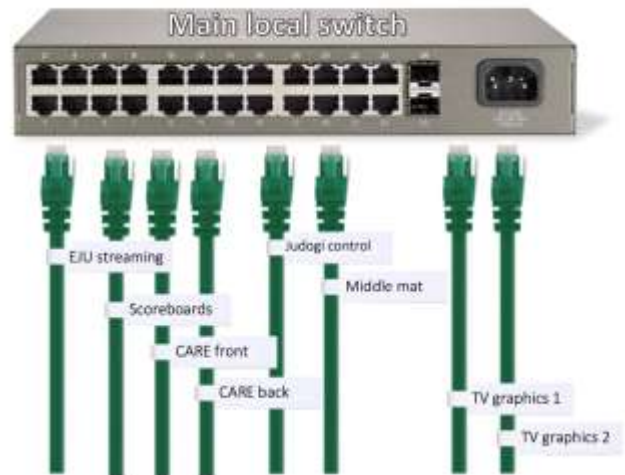

Key points:

- Whenever a cable is ready:
 - Label with target location
 - Ping test
- No broken latches!



19.12 Internet Network

CAT-6 LAN cables

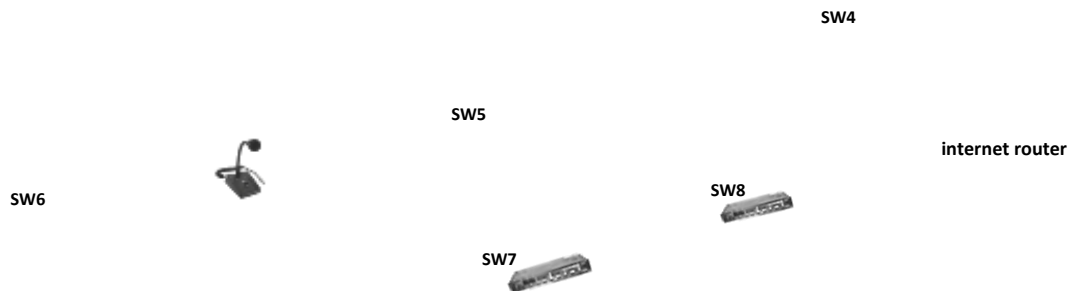

Internet speed – dedicated to EJU exclusive:

- Download speed: **100 MBit/s** or more
 - Upload speed: **100 MBit/s** or more
- (Values tested to Frankfurt using www.speedtest.net)

Internet for Media/others is handled by organiser

All Internet connections need to be wired. Additionally, IJF will create own wireless network

Network switches		<input type="checkbox"/>
SW4	EJU main internet switch located at EJU streaming studio	<input checked="" type="checkbox"/>
SW5	Middle-mat internet switch (8 port)	<input type="checkbox"/>
SW6	Event control internet switch (8 port)	<input type="checkbox"/>
SW7+8	Staff internet switches (8 port)	<input type="checkbox"/>

EJU main internet switch

Order of cabling		<input type="checkbox"/>
11	Cable from main internet switch to middle-mat internet switch	<input type="checkbox"/>
12	Cables from middle-mat internet switch to speakers place	<input type="checkbox"/>
13	Cable from middle-mat switch to event control place	<input type="checkbox"/>
14	Cable from middle-mat internet switch to staff internet switches	<input type="checkbox"/>
15	Six cables from each staff internet switches to nearby EJU staff places	<input type="checkbox"/>

Middle mat

For main internet line do not use IP 192.168.2.x as it is reserved for the local network!

Key points:

- Whenever a cable is ready:
 - Label with target location
 - Ping test
- No broken clips



19.13 Local Network 10 Gbit



IT Requirements

Local Network 10 GBit

Optional if FairReplay is used



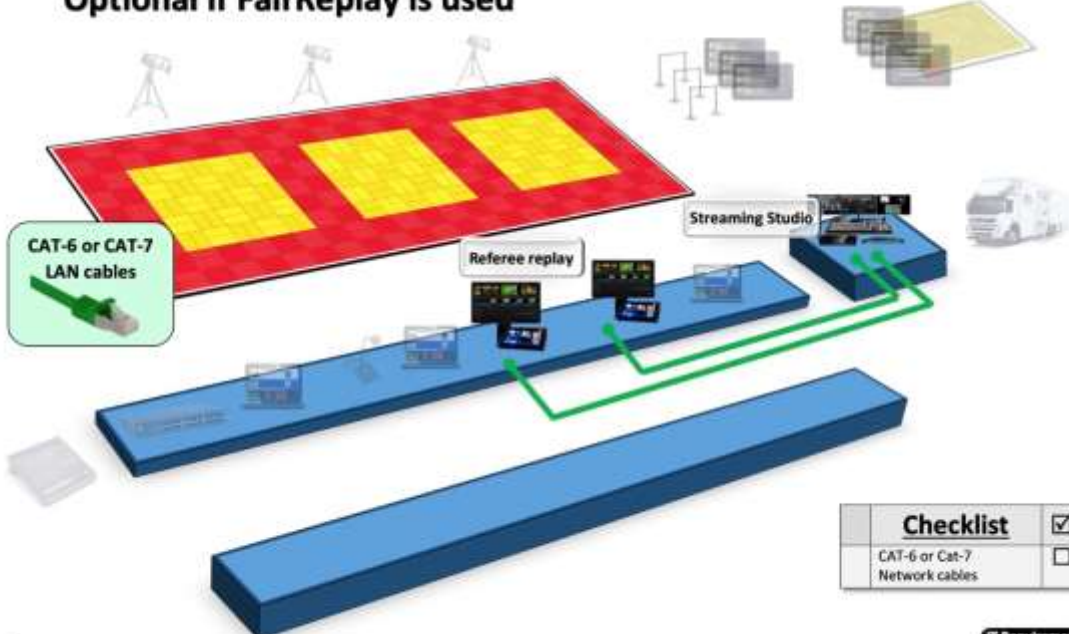

Checklist		<input checked="" type="checkbox"/>
CAT-6 or Cat-7 Network cables		<input type="checkbox"/>

IT Requirements

19.14 Scoreboards

LED board controller

MS Windows 10 required!



USB DI box

Connection from laptop via HDMI out

LED pannels scoreboard: >200 vertical pixel per meter recommended (min. 96 pixel/meter)

Checklist

- 1 LED screen 55" or bigger 16:9, HDMI input
- 1 LED board controller
- 1 converter HDMI to LED board input (if needed)
- 1 HDMI Splitter (1x in, 2x out)
- 1 Laptop
- 1 USB DI box
- 1 Scoreboard keyboard
- HDMI cables
- 1 Big active speaker
- XLR audio cables (from laptop to backup speaker and venue mixer)

19.15 Scoreboard Operators

2x

4x

6x

8x

Scoreboard operators from local organiser:

- >=18 years old
- English speaking
- Judo referee license

Introduction and briefing:

New users: Day before start of competition at 19:00 in the venue

Experienced: First day of competition, one hour before start in venue

Checklist

- List of names of all scoreboard operators

19.16 Gong & Audio Set-up

XLR audio cables



big **active speakers** with amplifier at **each** mat, independent from mixer

Jack connector (¼ inch). All other connections by **XLR**



USB DI box, like Peavey USB-P

Checklist

- Venue speaker system
- Professional audio mixer, connected to venue speaker system
- Active speakers with amplifier each tatami
- XLR cables
- 1 Jack connector (¼ Inch)

Check carefully for ground loop hum and buzzing noises!

At each mat: Additional big **active speakers** with **amplifier** and **XLR input**

- Used solely for gong signals from each mat as backup
- Directly connected to DI boxes from scoreboard laptops
- Gong signal must be heard in venue with noisy crowd

19.17 Video Cabling

HD-SDI cables BNC

HD-SDI video cameras with tripods needed for each mat

Use high quality HD-SDI cables (RG59, 75 ohm)

Use HD-SDI repeater or BNC <-> optical fibre for long distances!

Checklist

-
- HD-SDI video cameras with tripods for each mat
- HD-SDI video cables BNC
- HD-SDI distributors
- HD-SDI repeater/converter
- HD-SDI test monitor
- Reserve: HD-SDI cable role, BNC connectors & crimping tools

19.18 Video Camera operators

3x

6x

9x

12x

Camera operators from local organiser:

- >=18 years old
- English speaking
- Judo background

Introduction and briefing:

First day of competition, one hour before start in venue

Checklist

-
- List of names of all camera operators

19.19 Streaming Studio

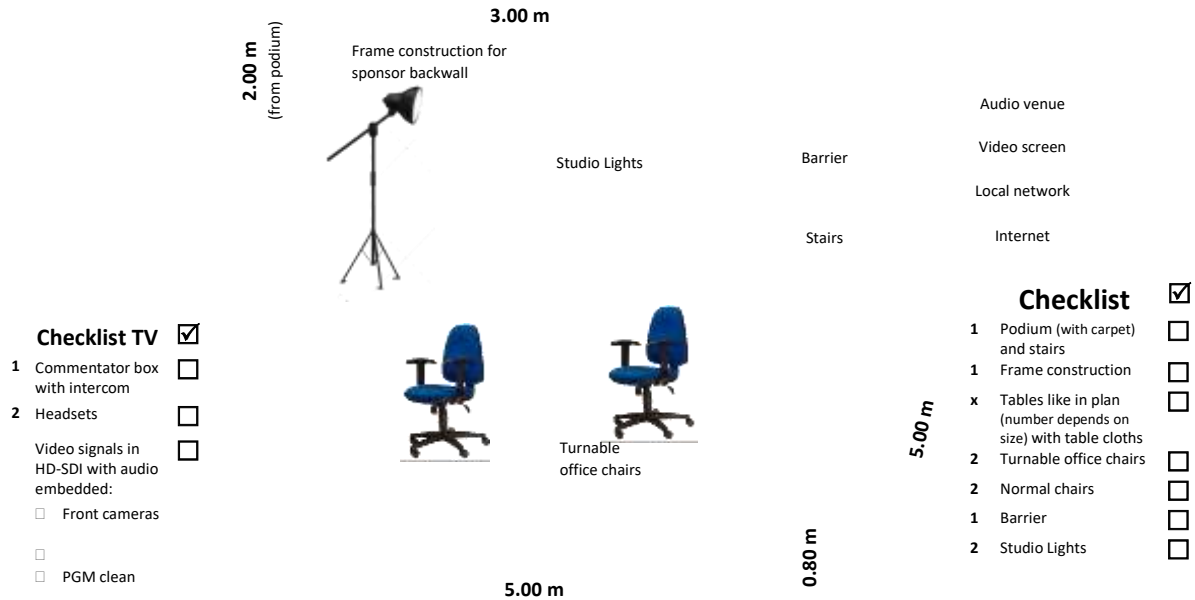

19.20 Information system

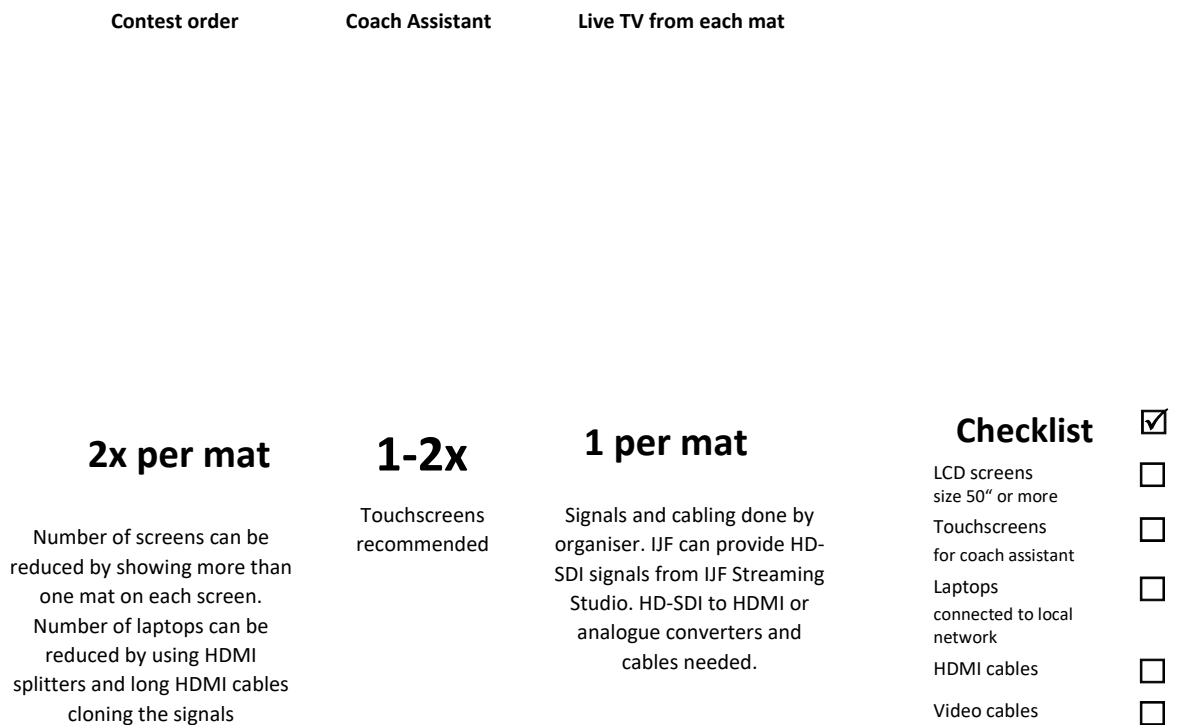

19.21 CARE System



IT Requirements
CARE System

Judges Replay
(if FairReplay not used)



Equipment Expert

For each tatami:

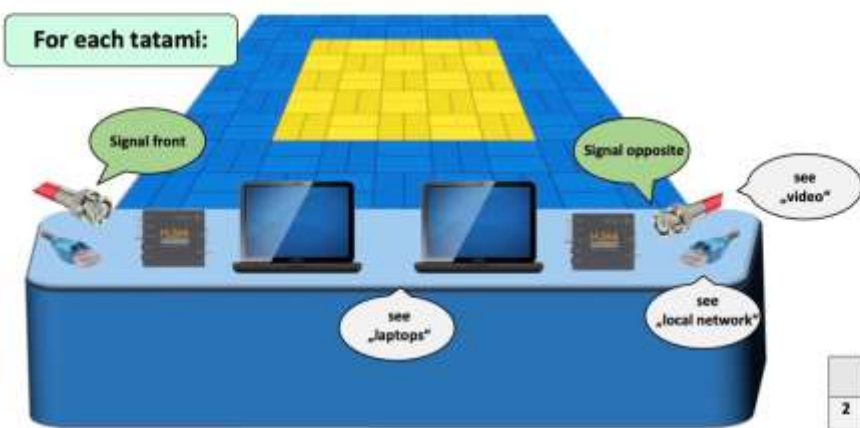

Signal front

Signal opposite

see „video“

see „laptops“

see „local network“

The official EJU/IJF video replay software has to be used

The organiser has to ensure that every contest is recorded from one site. The copy of recordings need to be stored on disk and uploaded after competition

Checklist		<input checked="" type="checkbox"/>
2	Laptops per mat	<input type="checkbox"/>
2	Blackmagic Design ProRecorder H.264	<input type="checkbox"/>
2	USB cable	<input type="checkbox"/>
	IJF CARE software	<input type="checkbox"/>

IT Requirements

19.22 Referee Radios

7x

14x

21x

28x

+

+

Checklist

-
- Radios
- Security headset
- Charger
- Responsible person*

Each tatami needs it's own frequency!

Responsible person should bring, charge every night and help referees with radio

19.23 After Competition

...keep running:

Electricity**Internet**

After the competition is finished our teams still need time to finalise the work
(interviews, video highlight editing, news uploading etc.)

Therefore, it is essential that **electricity, internet** and **lights** are kept on and intact until the last working person from EJU gives green light that it is no longer needed.

Important: Please inform **all** persons and companies involved in the dismantling on the **last day!**

20. IT Requirements - European Cup

20.1 Introduction

A proper IT set-up is essential for a successful competition. Please read & follow carefully!

- This document needs to be **forwarded** to the responsible persons and companies in charge of fulfilment. The **experts** in each field need to have these requirements as soon as possible.

- Every **detail** is important. If a specification cannot be fulfilled entirely or certain items cannot be delivered as described: please **communicate** this beforehand with the EJU IT department. All changes need approval.

- The installation time and effort are easily underestimated. Finishing the set-up late in the night before start of competition is risky. All needs to be properly tested. Set the right **priorities!**

- If there are any questions, please don't hesitate to contact EJU IT department

20.2 Accreditation cards

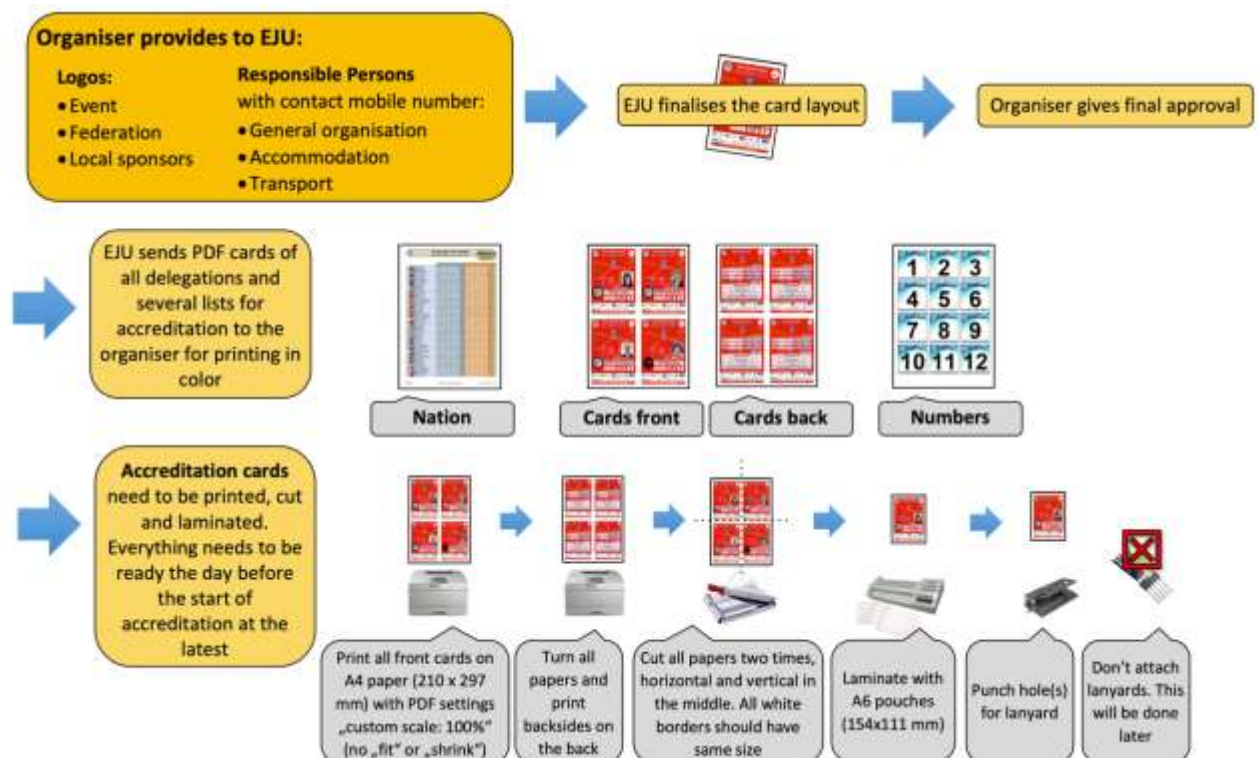

20.3 Accreditation Setup



- The room needs to be set-up the evening before the start of accreditation. This includes delivery of all equipment plus the printed and laminated accreditation cards
- Network IP addresses from printers need to be set manually to 192.168.2.8 and 192.168.2.9
- The same printers (plus toners) need to be taken afterwards to the draw and then to the venue

Checklist		<input checked="" type="checkbox"/>
2	Color laser printer: <ul style="list-style-type: none"> • 20 ppm or faster • network connection 	<input type="checkbox"/>
2	Complete set of toner	<input type="checkbox"/>
1	Copy machine	<input type="checkbox"/>
2	Laminating machines	<input type="checkbox"/>
2	Paper cutter	<input type="checkbox"/>
2	Hole puncher	<input type="checkbox"/>
	Paper A4	<input type="checkbox"/>
	Laminating pouches Exact size: 154x111 mm	<input type="checkbox"/>
	Lanyards	<input type="checkbox"/>
5	Multi-outlet power strips	<input type="checkbox"/>
	Wireless Internet	<input type="checkbox"/>

20.4 Draw

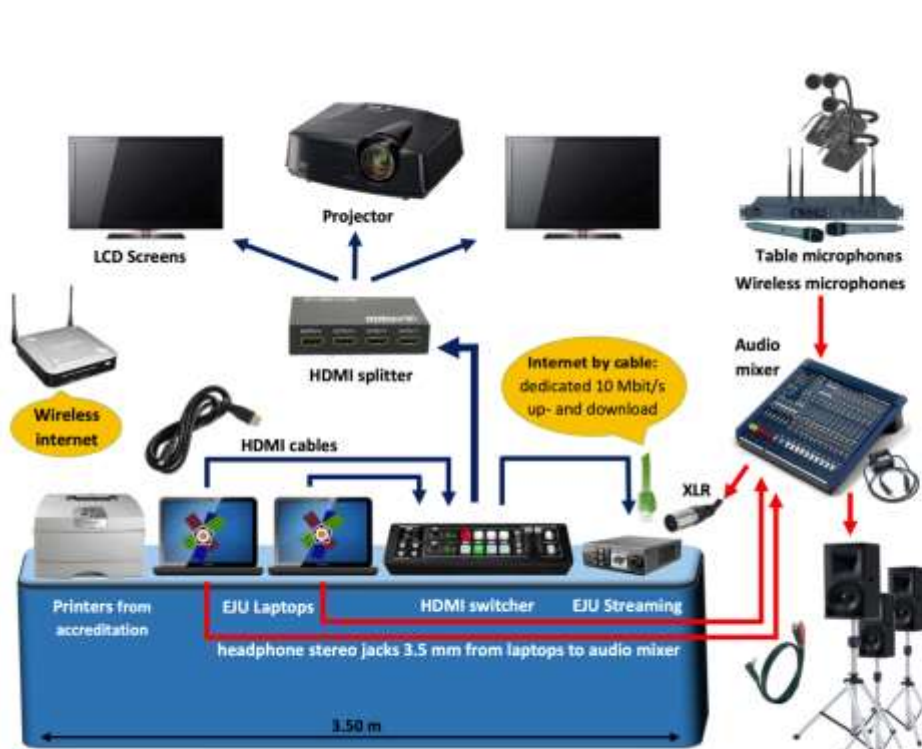

- The same printers (plus toners) must then be taken to the venue



Checklist		<input checked="" type="checkbox"/>
1	Projector (HDMI input, 3000 ANSI Lumen or more)	<input type="checkbox"/>
2	LCD screens* (50", HDMI)	<input type="checkbox"/>
1	HDMI switcher (3x in, 1x out, seamless switching)	<input type="checkbox"/>
1	HDMI splitter (1x in, 3x out)	<input type="checkbox"/>
6	Cabled microphones	<input type="checkbox"/>
2	Wireless microphones	<input type="checkbox"/>
1	Audio mixer (+cables)	<input type="checkbox"/>
	Speakers (+cables)	<input type="checkbox"/>
3	Audio cables	<input type="checkbox"/>
3	Ground loop isolators (for audio signal from laptops)	<input type="checkbox"/>
	HDMI cables	<input type="checkbox"/>
	Internet wireless	<input type="checkbox"/>
	Internet by cable (10 Mbit/s up- and download)	<input type="checkbox"/>
2	Copy machines (50 ppm or faster, with sorting function)	<input type="checkbox"/>

20.5 Power

1x

1 x Uninterruptible Power Supplies (UPS):

- Min. power each UPS:
980 Watts / 1440 VA
- Waveform Type:
pure Sine wave

Pure sine wave

Simulated sine

Square

Exclusive power lines:

- 2x optional streaming studio
(different phase/circuit than lighting equipment!)
- 1x Event IT

Multi-outlet power strips:

- With 5 or more plugs each
- No switches

Checklist

- 1 UPS as specified
- Multi-outlet power strips
- Power cable extensions

20.6 Electricity points

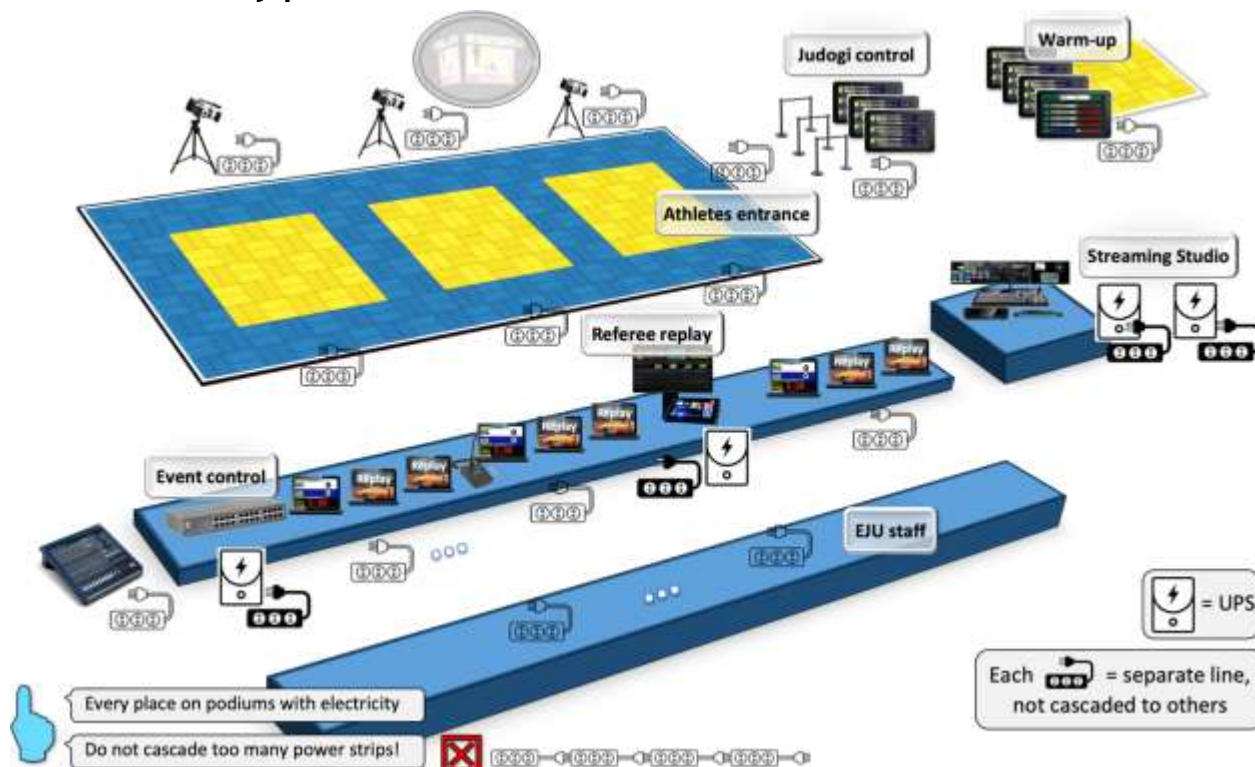

20.7 Laptops

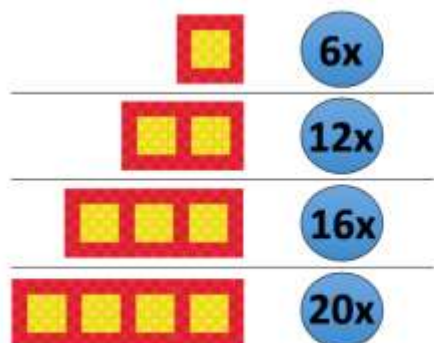

local IP 192.168.2.x	
Location	x
IJF Server	3
Scoreboard	11, 12, 13,...
Judogi control	21, 22, 23,...
Warm-up	31, 32, 33,...
CARE front	41, 42, 43,...
CARE opposite	51, 52, 53,...

Subnet: 255.255.255.0
 Gateway: empty
 DNS: empty

Hardware Requirements:

- Up-to-date model
- For scoreboards:
 - 8 GB RAM
 - Resolution 1920x1080
- 200 GB disk space free
- Network input
- HDMI output
- Mouse

Operating System Requirements:

- MS Windows 10 Professional
- English language version and keyboard
- Clean installation
- No login password
- Windows firewall: file and printer sharing exception enabled
- No security suite/Antivirus software/3rd party firewall installed
- Screensaver/power saver disabled
- Reduced screen brightness on battery

20.8 Monitors

3x

HDMI input

All TFT monitors:

- Size: 23"-26"
- Resolution: 1920x1080 Full HD
- Format 16:9
- Input: HDMI

Checklist

- 6 Full-HD TFT monitors with HDMI input

20.9 Local Network



main local switch

- All cables must be **labelled** at main switch!
- Local network must be physically **separated** from internet network!
- Scoreboard** laptops must be cabled **directly** to main local switch, no other switch in between!

Checklist

- 2 24-port gigabit switches
- 3 8-port gigabit switches
- CAT-6 Network cables
- Reserve cable role, R45 plugs and crimping tools

Network switches		<input type="checkbox"/>
SW1	Main local switch (24 port)	<input checked="" type="checkbox"/>
SW2	Middle-mat local switch (8 port)	<input type="checkbox"/>
SW3	Judogi-control local switch (8 port)	<input type="checkbox"/>
SW4	Warm-up area local switch (8 port)	<input type="checkbox"/>
SW5	Optional: TV-graphics local switch (4 port)	<input type="checkbox"/>

Order of cabling		<input type="checkbox"/>
1	Cable from main local switch to EJU streaming studio place	<input type="checkbox"/>
2	Cables from main local switch to scoreboard laptops mat 1, 2, 3, ...	<input type="checkbox"/>
3	Cables from main local switch to CARE laptops mat 1, 2, 3, ...	<input type="checkbox"/>
4	Cable from main local switch to judogi-control local switch	<input type="checkbox"/>
5	Cables from judogi-control switch to judogi-control laptops	<input type="checkbox"/>
6	Cable from judogi-control switch to warm-up area local switch	<input type="checkbox"/>
7	Cables from warm-up area switch to warm-up area laptops	<input type="checkbox"/>
8	Cable from main local switch to middle-mat local switch	<input type="checkbox"/>
9	Cables from middle-mat-switch to EJU replay machine	<input type="checkbox"/>
10	Cable and back-up cable from main local switch to TV-graphics place (using additional switch if distance too long)	<input type="checkbox"/>

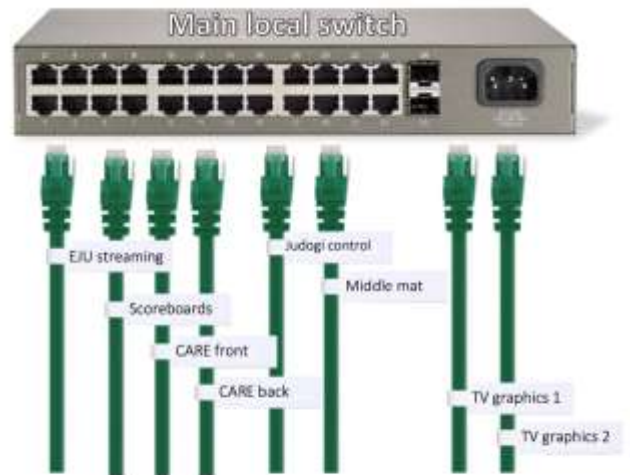

Key points:

- Whenever a cable is ready:
 - Label with target location
 - Ping test
- No broken latches!



20.10 Internet Network

CAT-6 LAN cables



SW6



SW5

SW7



SW4



internet router

Internet speed – dedicated to EJU exclusive:

- Download** speed: **100 MBit/s** or more
- Upload** speed: **100 MBit/s** or more

(Values tested to Frankfurt using www.speedtest.net)

Internet for Media/others is handled by organiser

All Internet connections need to be wired. Additionally, IJF will create own wireless network

Network switches		<input type="checkbox"/>
SW4	EJU main internet switch located at EJU streaming studio	<input checked="" type="checkbox"/>
SW5	Middle-mat internet switch (8 port)	<input type="checkbox"/>
SW6	Event control internet switch (8 port)	<input type="checkbox"/>
SW7+8	Staff internet switches (8 port)	<input type="checkbox"/>

EJU main internet switch

Order of cabeling		<input type="checkbox"/>
11	Cable from main internet switch to middle-mat internet switch	<input type="checkbox"/>
12	Cables from middle-mat internet switch to speakers place	<input type="checkbox"/>
13	Cable from middle-mat switch to event control place	<input type="checkbox"/>
14	Cable from middle-mat internet switch to staff internet switches	<input type="checkbox"/>
15	Six cables from each staff internet switches to nearby EJU staff places	<input type="checkbox"/>

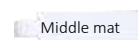

Key points:

- Whenever a cable is ready:
 - o Label with target location
 - o Ping test
- No broken clips



For main internet line do not use IP 192.168.2.x as it is reserved for the local network!

20.11 Local Network 10 Gbit



IT Requirements

Local Network 10 GBit

Optional if FairReplay is used



Network Expert

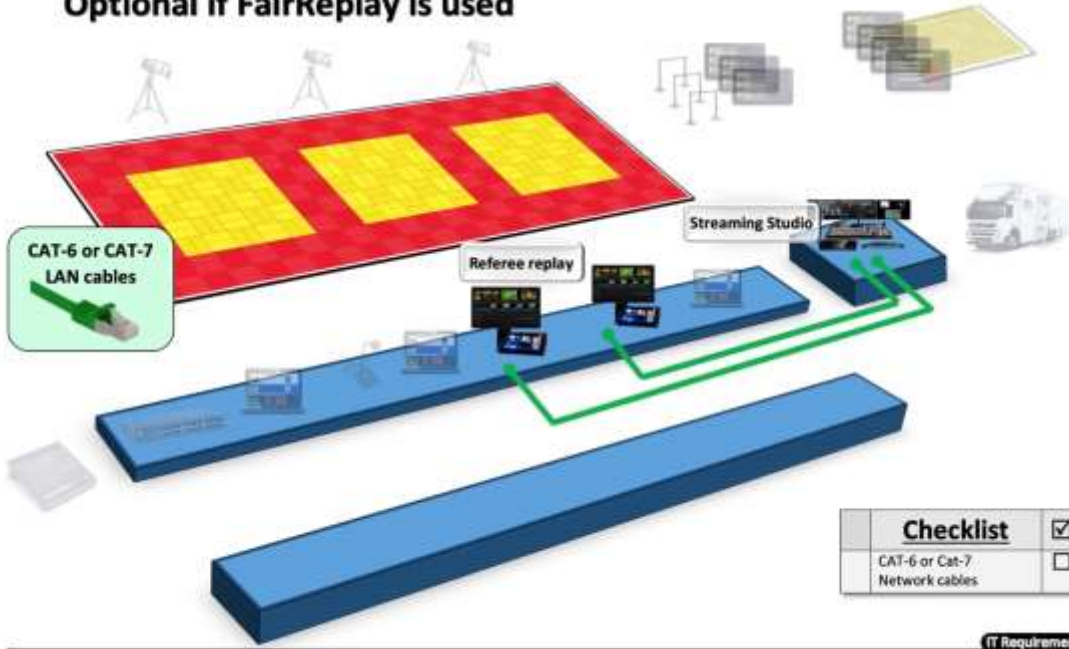

Checklist		<input checked="" type="checkbox"/>
CAT-6 or Cat-7 Network cables		<input type="checkbox"/>

IT Requirements

20.12 Scoreboards

MS Windows 10 required!



Connection from laptop via HDMI out

- | Checklist | <input checked="" type="checkbox"/> |
|---|-------------------------------------|
| 1 LED screen 50" or bigger 16:9, HDMI input | <input type="checkbox"/> |
| 1 HDMI Splitter (1x in, 2x out) | <input type="checkbox"/> |
| 1 Laptop | <input type="checkbox"/> |
| 1 Scoreboard keyboard | <input type="checkbox"/> |
| HDMI cables | <input type="checkbox"/> |
| 1 Big active speaker | <input type="checkbox"/> |

20.13 Scoreboard Operators

2x

4x

6x

8x

Scoreboard operators from local organiser:

- >=18 years old
- English speaking
- Judo referee license

Introduction and briefing:

New users: Day before start of competition at 19:00 in the venue

Experienced: First day of competition, one hour before start in venue

Checklist

List of names of all scoreboard operators

20.14 Video Cabling

HD-SDI cables BNC

HD-SDI video cameras with tripods needed for each mat

Use high quality HD-SDI cables (RG59, 75 ohm)

Use HD-SDI repeater or BNC <-> optical fibre for long distances!

Checklist

- HD-SDI video cameras with tripods for each mat
- HD-SDI video cables BNC
- HD-SDI distributors
- HD-SDI repeater/converter
- HD-SDI test monitor
- Reserve: HD-SDI cable role, BNC connectors & crimping tools

20.15 Video Camera operators

3x

6x

9x

12x

Camera operators from local organiser:

- >=18 years old
- English speaking
- Judo background

Introduction and briefing:

First day of competition, one hour before start in venue

Checklist



List of names of all camera operators



20.16 Streaming Studio (optional)

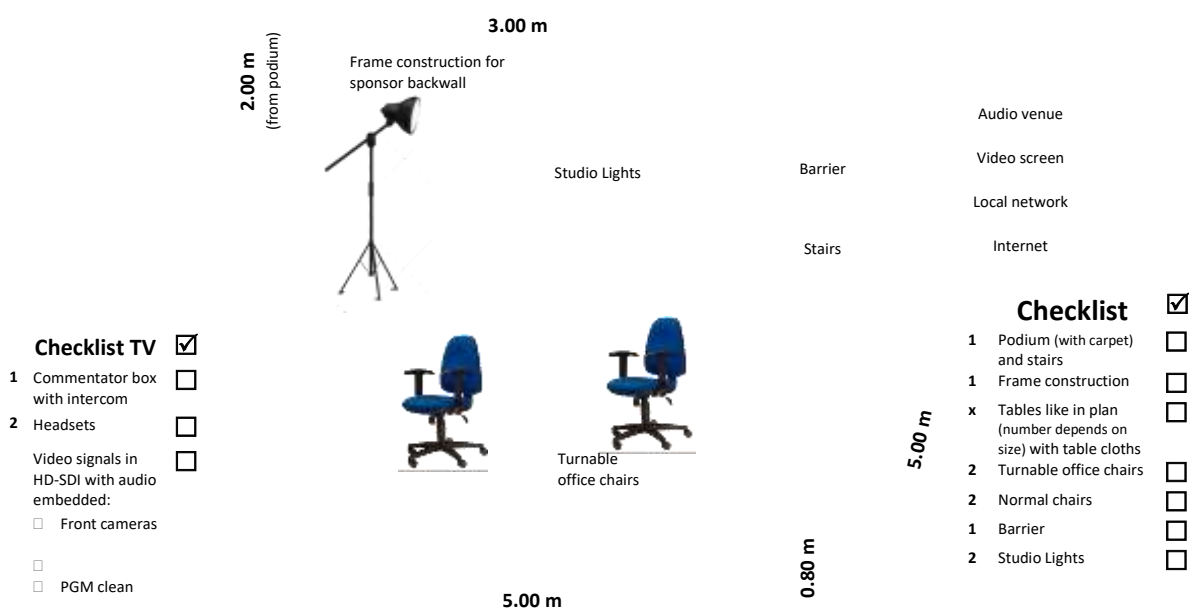

Checklist TV

-
- 1 Commentator box with intercom
- 2 Headsets
- Video signals in HD-SDI with audio embedded:
- Front cameras
- PGM clean

Checklist

-
- 1 Podium (with carpet) and stairs
- 1 Frame construction
- x Tables like in plan (number depends on size) with table cloths
- 2 Turnable office chairs
- 2 Normal chairs
- 1 Barrier
- 2 Studio Lights

20.17 Information system

Contest order

Coach Assistant

Live TV from each mat

2x per mat

Number of screens can be reduced by showing more than one mat on each screen.
Number of laptops can be reduced by using HDMI splitters and long HDMI cables cloning the signals

1-2x

Touchscreens recommended

1 per mat

Signals and cabling done by organiser. IJF can provide HD-SDI signals from IJF Streaming Studio. HD-SDI to HDMI or analogue converters and cables needed.

Checklist

-
- LCD screens size 50" or more
- Touchscreens for coach assistant
- Laptops connected to local network
- HDMI cables
- Video cables

20.18 CARE System

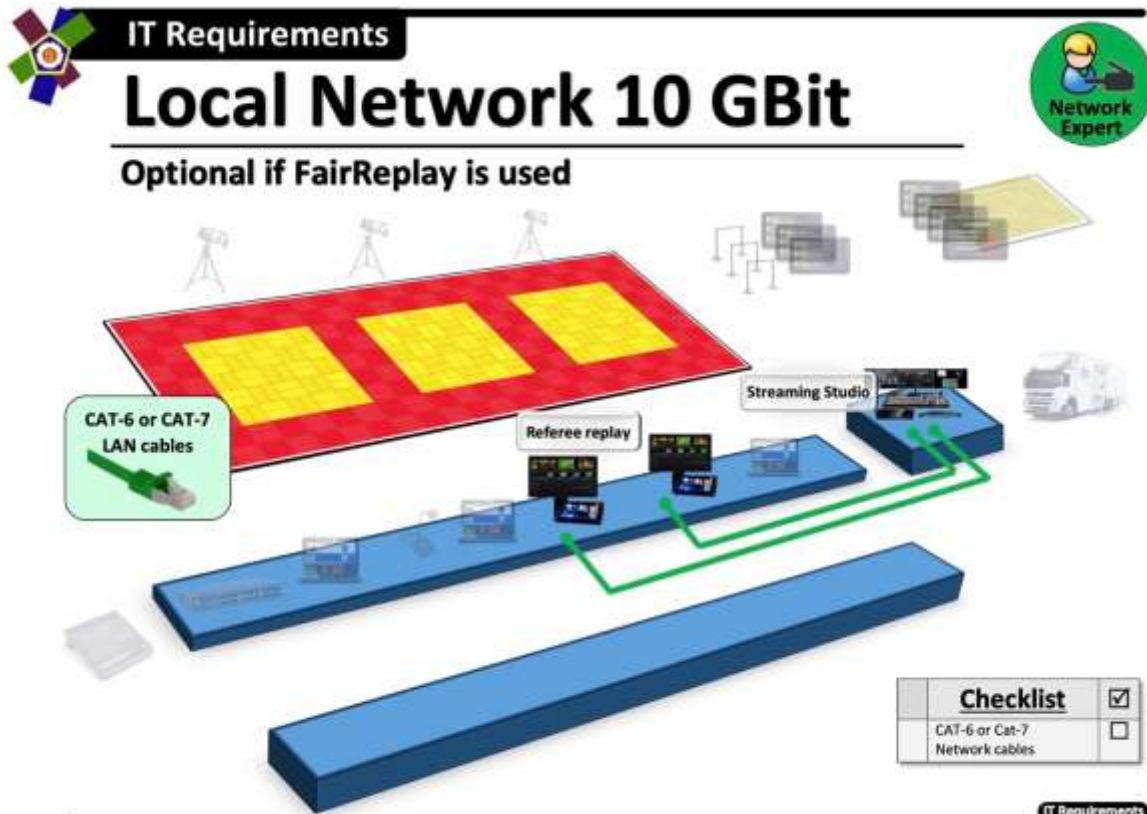

20.19 Referee Radios

7x

14x

21x

28x

+

+

Checklist

-
- Radios
- Security headset
- Charger
- Responsible person*

Each tatami needs it's own frequency!

Responsible person should bring, charge every night and help referees with radio